

Paper presented at
Deep Foundations Institute Symposium
at the Westin Bayshore Hotel, Vancouver, B.C., Canada,
April 14-16, 1987.

**Predicting Axial and Lateral Pile Behaviour
in Deltaic Soils Using In-Situ Testing Methods**

by

Michael P. Davies,¹ John A. Howie,¹ and
Richard G. Campanella¹

Abstract

The prediction of axially and laterally loaded pile behaviour is a complex engineering problem. Traditional methods of data collection and subsequent analyses are frequently in error when compared to full-scale load tests. In-situ testing, using advanced electronic tools, provides a means by which representative field data may be obtained. This paper presents the use of such in-situ data in predicting axially loaded pile capacity and laterally loaded pile behaviour. These predictions are compared with full-scale pile load test results from steel pipe piles in deltaic sediments.

¹Dept. of Civil Engineering, University of British Columbia, 2324 Main Mall, Vancouver, B.C., Canada, V6T 1W5

**Predicting Axial and Lateral Pile Behaviour
in Deltaic Soils Using In-Situ Testing Methods**

by

Michael P. Davies, John A. Howie, and

Richard G. Campanella

Introduction

In order that a piled foundation may be designed safely and economically, its behaviour under load must be accurately predicted and ideally a full-scale pile load test should be performed. Full-scale load tests tend to be very expensive and are therefore often impractical. Predictive methods require an accurate assessment of the properties of the soil into which the pile is to be placed. In-situ testing methods offer an excellent means by which to accurately obtain these soil properties.

A total of thirteen static axial capacity methods were used to predict the results obtained from eight full-scale pile load tests on six different piles. These methods, separated into direct and indirect classes, used data obtained from the cone penetration test. The cone penetration test can be considered to be a model displacement pile.

Two methods of predicting lateral load-deflection using in-situ data have been investigated. One method uses pressuremeter data and the other uses flat plate dilatometer data. These predictions are compared with full-scale lateral load tests on three piles of differing size.

In both the axial and lateral load cases, the preferred methods of analysis are identified. It is shown that excellent agreement can be obtained for predicting measured pile behaviour using several methods.

In-Situ Testing Methods

Modern in-situ tests of sophistication that can supply repeatable results with equally sophisticated methods of data interpretation are becoming increasingly available to the engineer. The four main reasons that these tests are becoming increasingly popular are listed by Mitchell et al (1978):

- 1) The ability to determine properties of soils, such as sands and offshore deposits, that cannot be easily sampled.
- 2) The ability to avoid some of the difficulties of laboratory testing, such as sample disturbance and the proper simulation of in-situ stresses, temperature, and chemical and biological environments.
- 3) The ability to test a larger volume of soil than can be conveniently tested in the laboratory.
- 4) The increased cost effectiveness of an exploration and testing program using in-situ methods.

A laboratory test must reproduce the in-situ state of stress whereas an in-situ test invariably begins at this state. The mere fact that an in-situ test must be conducted with reference to the existing in-situ stress state is, however, an important limitation in itself. In-situ testing somewhat alters the stress field around the device used simply due to the insertion of the device into the ground. However, in contrast to laboratory testing, in-situ testing cannot simulate large changes in stress.

Robertson (1985) and Wroth (1984) provide excellent discussions of both the in-situ testing methods available and the interpretation of these tests for foundation design purposes.

The three main testing procedures used for this study will be briefly described herein.

Piezometer Cone Penetration Test

The cone penetration test (CPT) is a quasi-static penetration device. The CPT was originally developed in Europe but is now becoming more accepted in North America and elsewhere.

For this study, electric cones with built-in load cells that measure the end resistance (q_c) and sleeve friction (f_s) continuously were used. A schematic of an electric cone developed at UBC is shown in Fig. 1. It is this cone that was mainly used in this study. This cone, in accordance with ASTM D3441-79, has a 10 cm² cone tip with a 60° conical tip. The friction sleeve has a standard 150 cm² surface area. In addition to the q_c and f_s measurements, many cones now incorporate a pore pressure transducer. The addition of the pore pressure transducer allows continuous measurement of pore pressure response during testing providing valuable information for determining soil gradation as well as allowing equilibrium pore pressures to be obtained from dissipation data.

The advantages of the CPT are: rapid procedure; continuous logging; good repeatability; and easy standardization. Some of its limitations include: inability to penetrate gravel; no sample obtained; high initial cost; and technical back-up facilities required. Soil conditions such as the deltaic deposits of the Lower Mainland are ideally suited to cone testing.

As for any electronic instrument, proper calibration and periodic calibration checks are essential to ensure all electric cones are functioning properly.

Robertson and Campanella (1986) provide a comprehensive review of equipment, testing procedures and data interpretation for electric cone testing.

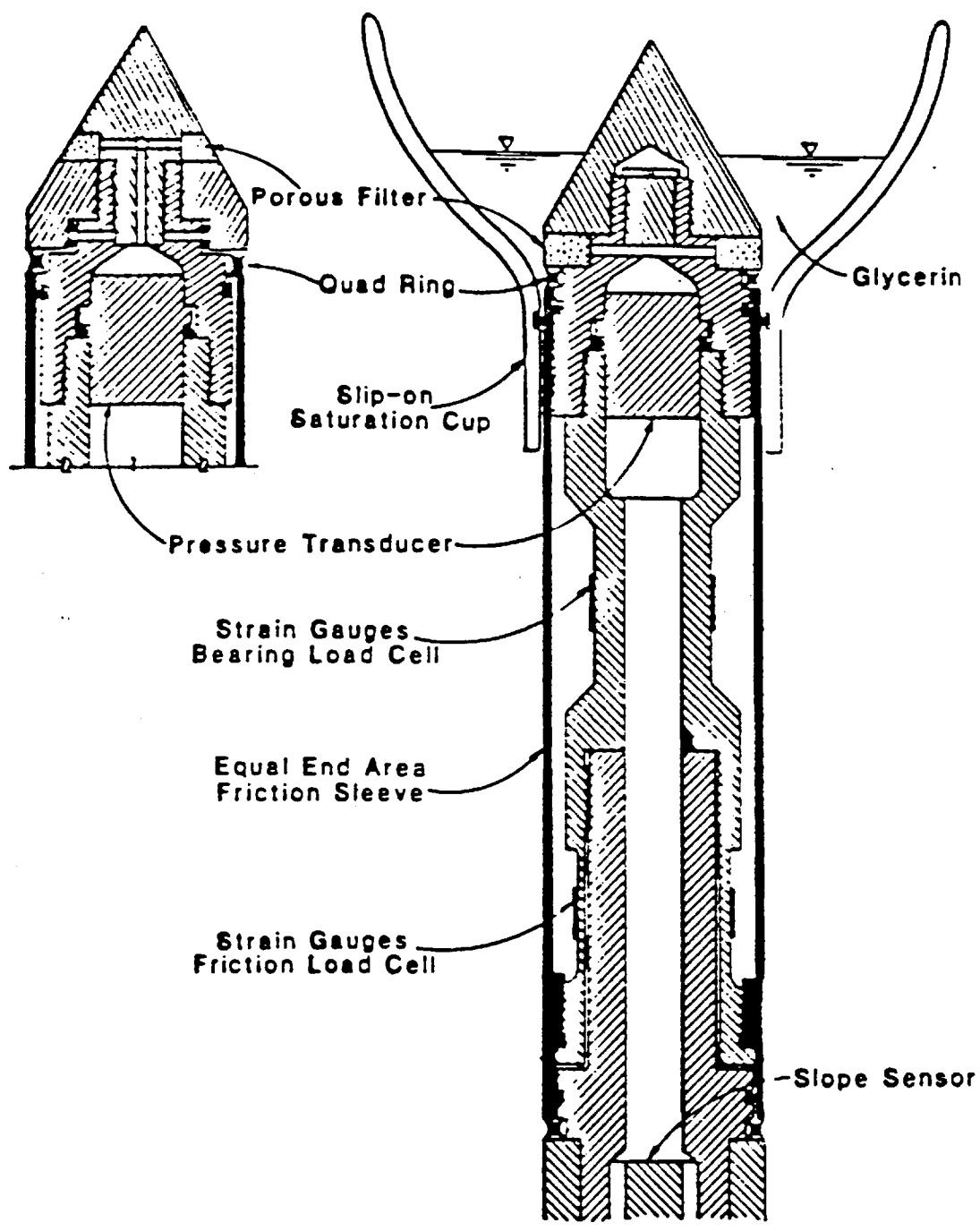

Fig. 1. UBC Piezometer Friction Cone Showing Tip Design to Relocate Porous Filter and Allow Easy Saturation with Glycerin (After Robertson and Campanella, 1986)

An interpreted CPT profile is shown in Fig. 2. Note the comprehensive nature of the data obtained using the cone. This 75 m sounding was completed within an eight hour day.

Full Displacement Pressuremeter Test

The pressuremeter was initially developed by L. Ménard in 1954 in France as a "specific test" tool to obtain a measure of strength and stiffness of soils and rocks. The pressuremeter test is carried out by inflating a membrane laterally against the soil. The relationship between pressure and the amount of expansion is recorded. Ménard-type pressuremeters are placed in pre-bored holes and so the soil being tested is disturbed to some degree. Recognizing this, Ménard developed standard testing procedures and developed semi-empirical foundation design methods using pressuremeter results.

The self-boring pressuremeter (SBPMT), developed independently in Britain and France in 1972, was designed to be inserted with minimum soil disturbance and has been found to work well in soft clays for determining earth pressure coefficients (K_0) and shear strength. In sands, however, some disturbance is inevitable. Self-boring pressuremeters are expensive, require a great deal of technical back-up and are limited to use in soils where $D_{50} < 5$ mm.

A recent development is the full-displacement (FDPMT) or cone pressuremeter, in which the pressuremeter is attached behind the cone tip and is pushed into the ground. This test does cause soil disturbance, but the disturbance is essentially the same each time. Hughes and Robertson (1985) present test results which indicate good agreement between values of soil stiffness obtained by self-boring and full-displacement pressuremeters. The

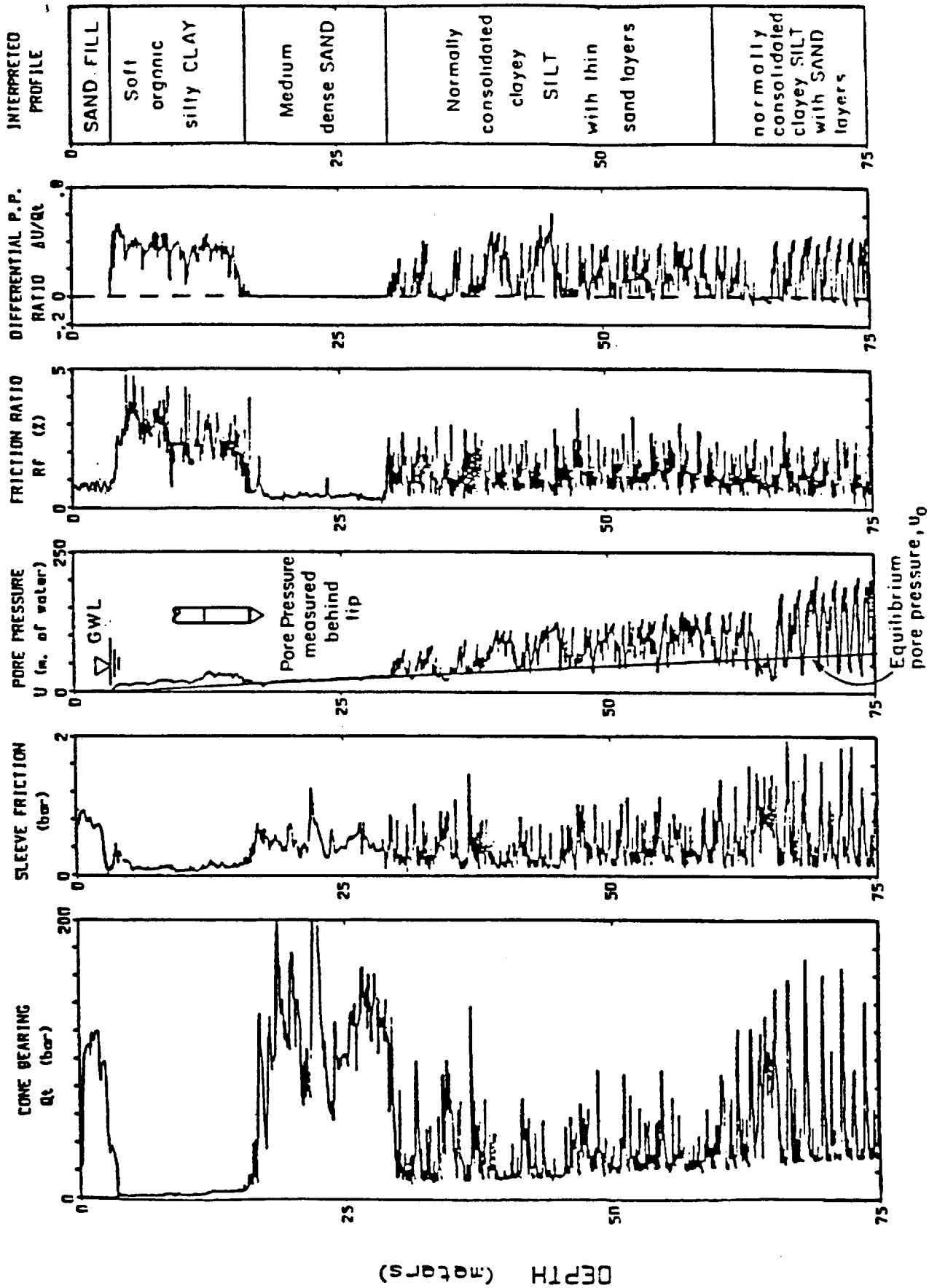

Fig. 2. Soil Profile for Pile Research Site from CPT
(1 bar = 100 kPa)

great advantage of the cone pressuremeter is that stratigraphic logging and pressure-expansion curves can be obtained in the same sounding.

For this study, two full-displacement pressuremeters were used. One of these was the UBC Cone Pressuremeter (Fig. 3). This instrument is 44 mm in diameter. Campanella and Robertson (1986) briefly summarize the research and development of the UBC Cone Pressuremeter. The other pressuremeter used has a diameter of 73 mm. Details of this probe can be found in Hughes and Robertson (1985).

A typical FDPMT curve is shown in Fig. 4.

Flat Plate Dilatometer Test

The flat plate dilatometer test (DMT) was developed in Italy by S. Marchetti in 1980. The dilatometer is a flat plate 95 mm wide, 14 mm thick and 220 mm in length. A flexible stainless steel membrane 60 mm in diameter is located on one side of the blade. A schematic representation of the dilatometer is shown in Fig. 5.

The dilatometer test involves inflating the flexible membrane to achieve a one millimetre deflection. The first reading (A) corresponds to the membrane lift-off pressure and the second reading (B) to the pressure required to cause the one millimetre deflection at the centre of the membrane. Readings A and B are corrected for both free-air effects of membrane seating and the effect of membrane curvature. The DMT is performed at 20 cm intervals of depth. This leads to a comprehensive, however discrete, profile.

Using the corrected dilatometer data of A and B (P_0 and P_1 , respectively), Marchetti (1980) developed empirical correlations to find several soil parameters. These correlations are all based upon three index

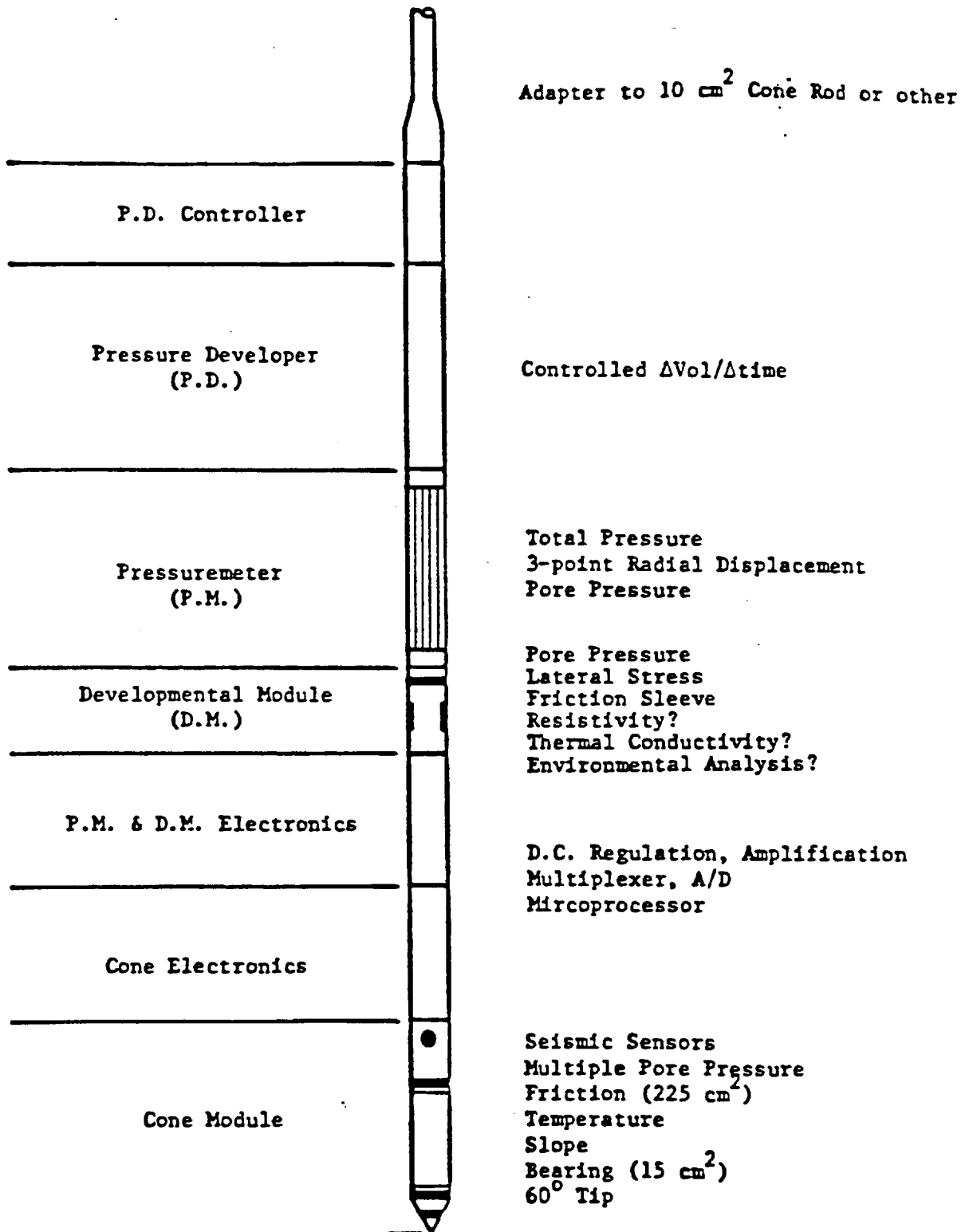

Fig. 3. Conceptual Design : UBC Cone Pressuremeter
(After Campanella and Robertson, 1986)

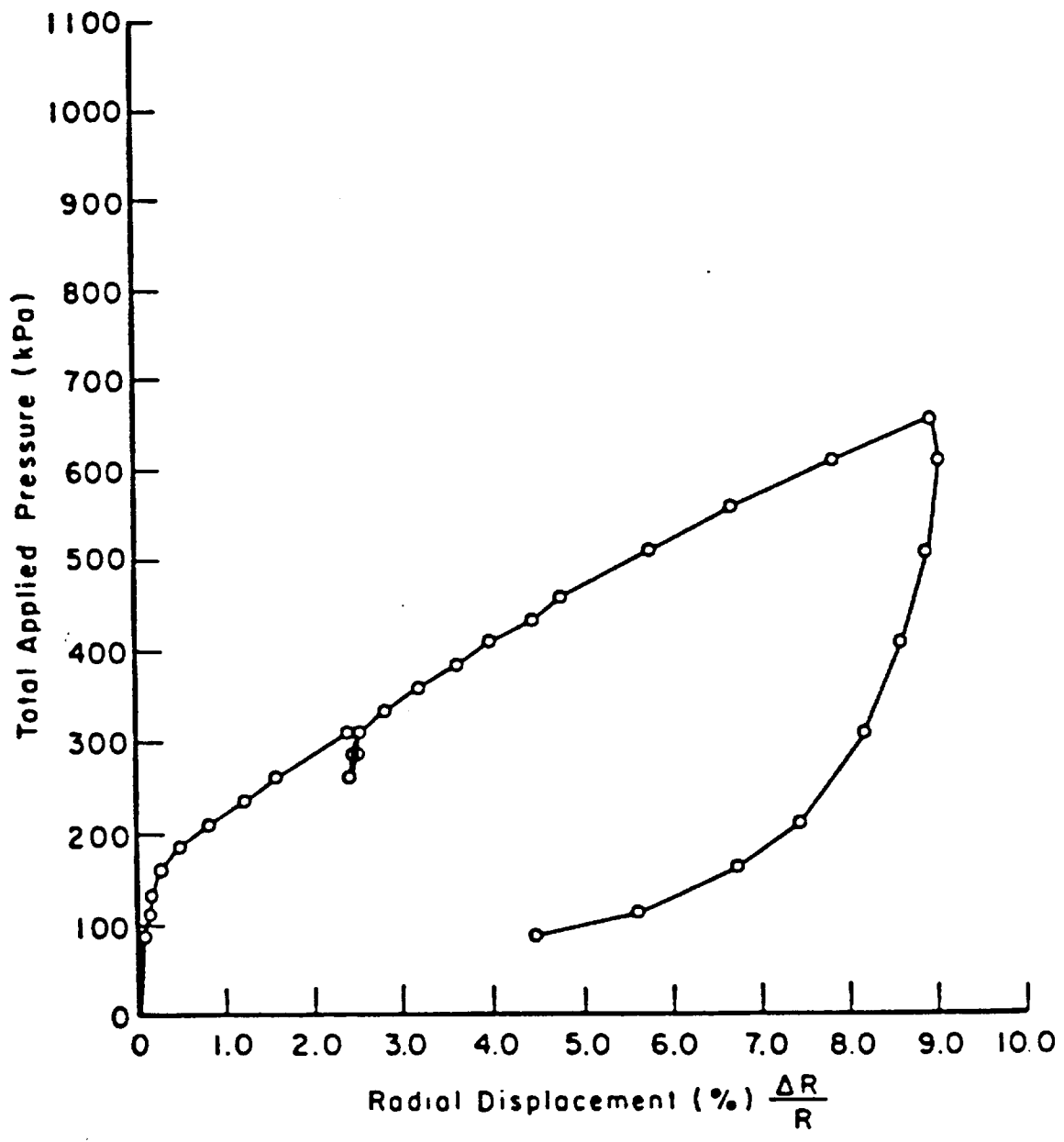

Fig. 4. Typical FDPMT Pressure-Expansion Curve
(After Hughes and Robertson, 1985)

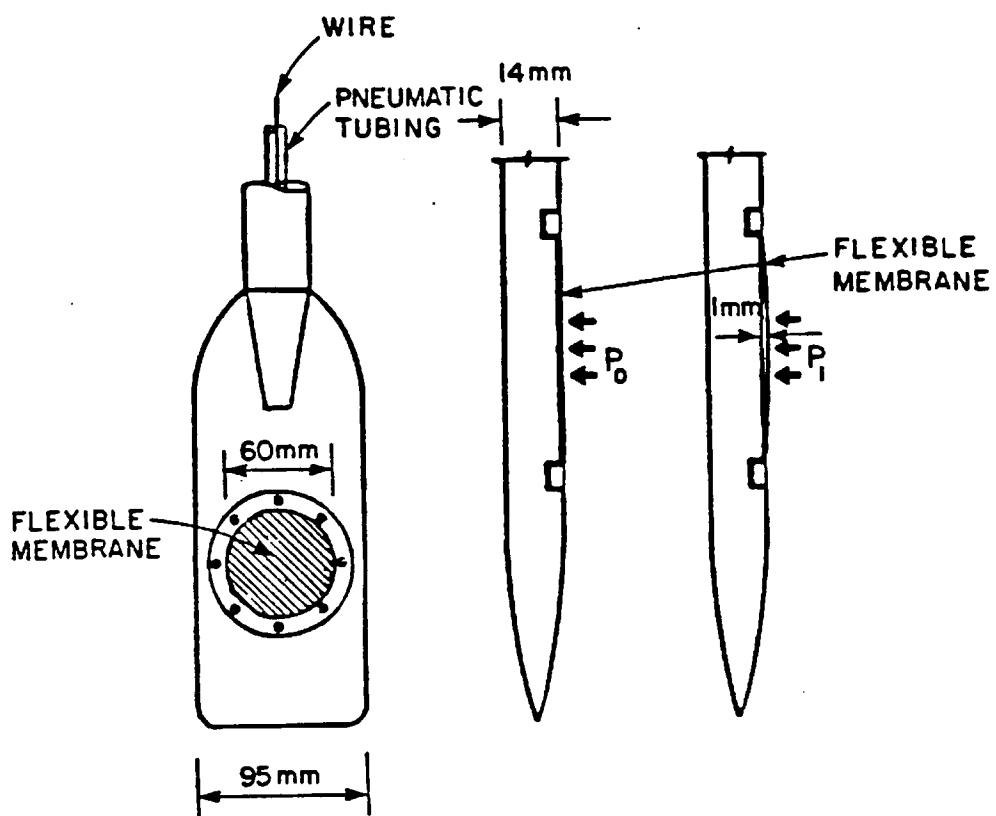

Fig. 5. Marchetti Flat Plate Dilatometer

parameters Marchetti gets from P_0 and P_1 . These are Material Index, I_d ; Horizontal Index, K_d ; and Dilatometer Modulus, E_d .

The DMT is a quick and easy test to use. Much more detailed discussions of the DMT and testing procedures are given in Marchetti (1980), Brown (1983), Campanella and Robertson (1983), and in Schmertmann (1986).

Typical DMT results are shown in Figs. 6 and 7. Fig. 6 shows the intermediate geotechnical parameters obtained whereas Fig. 7 shows the interpreted geotechnical parameters.

Research Site

The research site is located on Lulu Island which is within the post-glacial Fraser River Delta being formed by materials transported from both the ocean and from along the Fraser River system (Fig. 8).

The surficial geology of the Lulu Island region is typical of a former marine environment no longer dominated by tidal action. There is a prevalent deposit of organic silty clays that has been laid down in a quiescent swamp or marsh environment. Below this upper layer, which extends to roughly 15 m depth, a medium dense sand deposit, locally silty, prevails to roughly 25-30 m depth. This deposit is indicative of a very high energy depositional period and most likely represents a former channel bank of the Fraser River. Next, prevailing to roughly 60 m depth, exists a normally consolidated clayey silt containing thin sand layers. These materials were laid down in a much more quiescent environment than the sand above. Below this, probably extending for up to 150-200 m depth (Blunden, 1975), is a similar deposit except that the sand layers are much more prevalent and thicker (up to 0.5 m thick). Due to the non-uniformity of the deposits below 30 m, the depositional history most likely represents an alternatively turbulent and

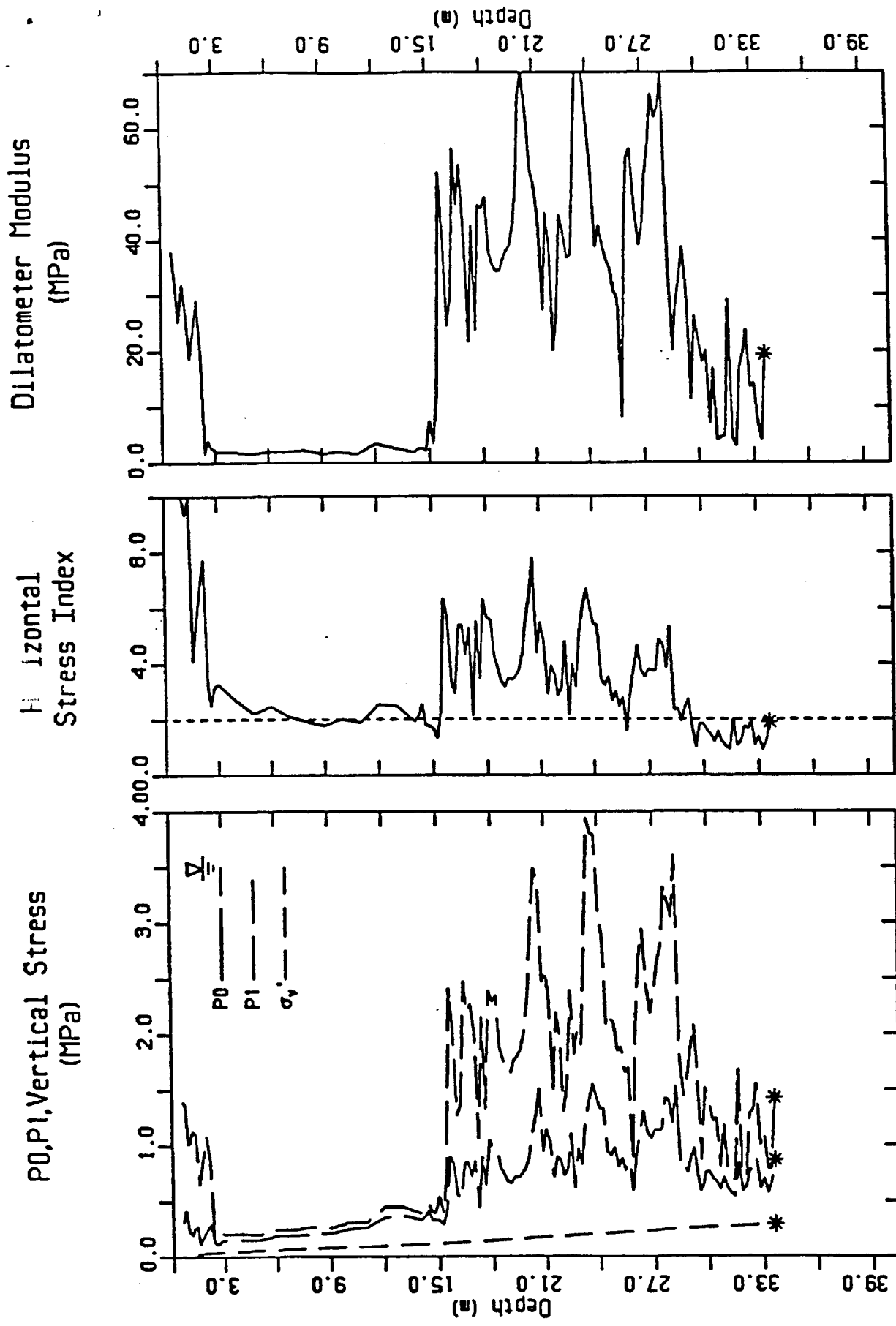

$$\frac{E_d}{34.6 \times (P_1 - P_0)}$$

$$\frac{K_d}{(P_0 - u) / \sigma_v'}$$

Fig. 6. Intermediate Geotechnical Parameters from DMT

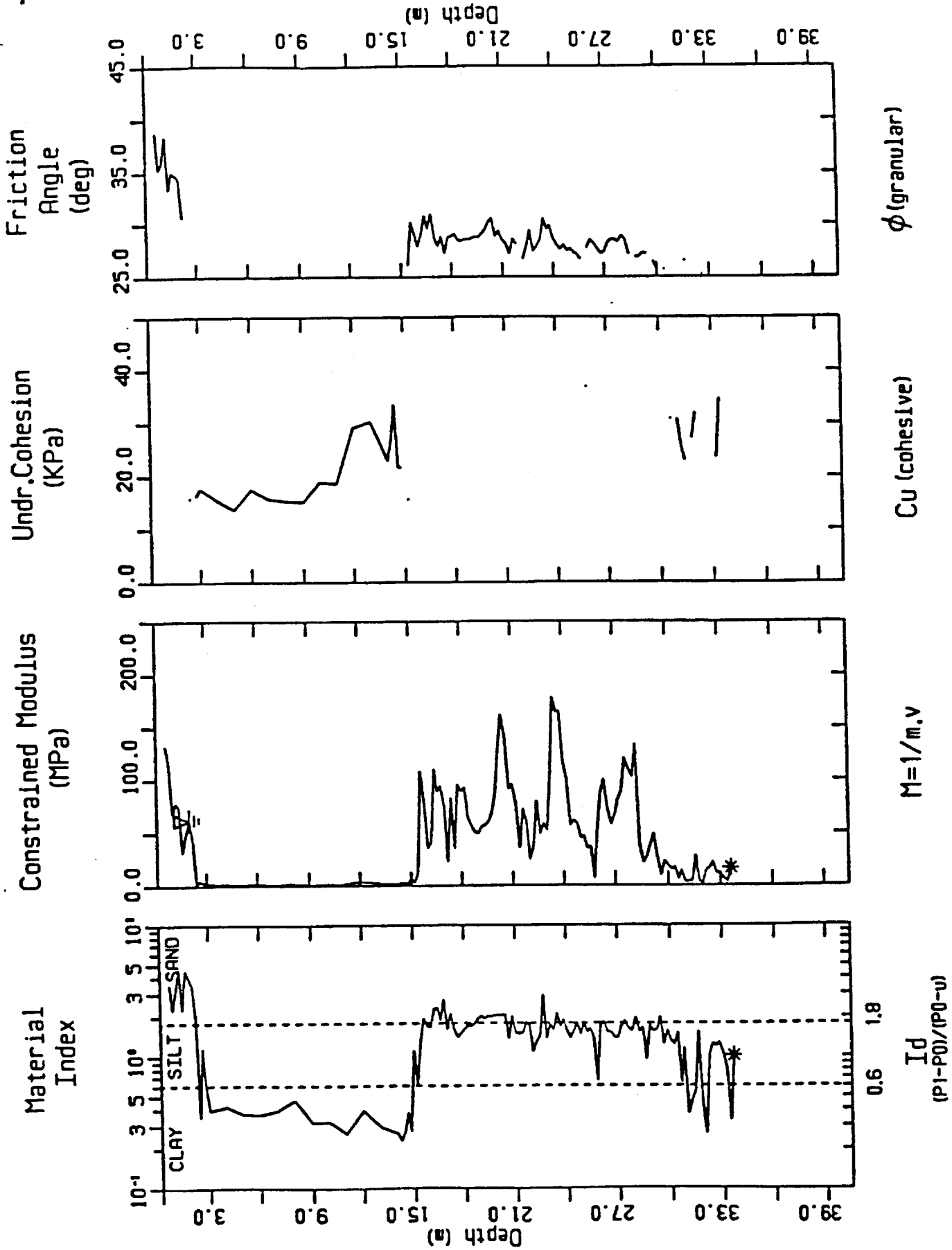

Fig. 7. Interpreted Geotechnical Parameters from DMT

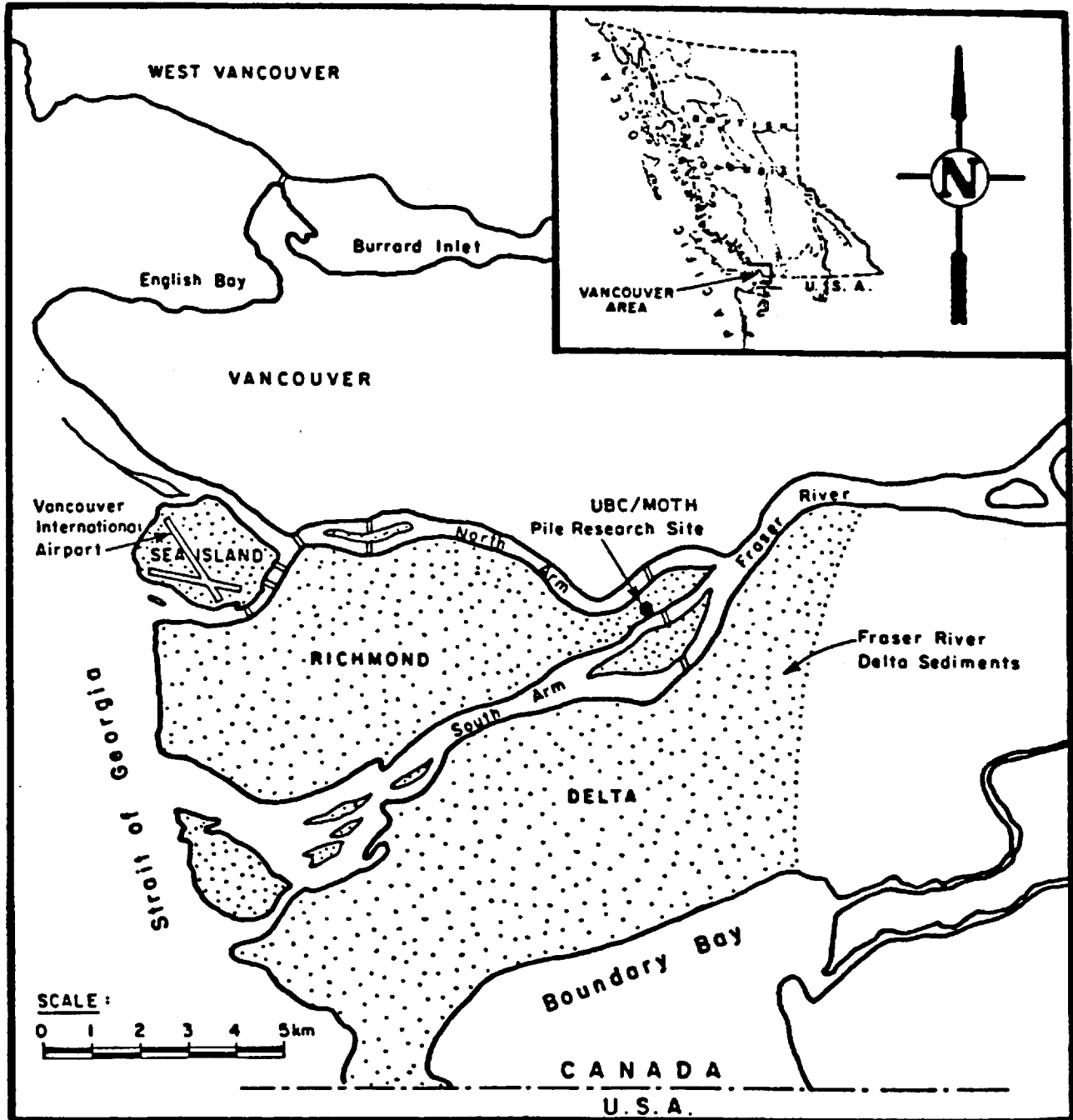

Fig. 8. General Location of Pile Research Site

quiescent environment being associated with possibly either a tidal flat facies, a marginal bank or an alluvial floodplain depositional environment. Fig. 2 (CPT profile) presents stratigraphic data from this site.

Upon the entire site, 2 to 4 m of non-homogeneous fill exists at the surface. For the purpose of facilitating in-situ testing, making pile driving possible, and studying lateral pile behaviour, the fill material was removed in the general area of the research piles. This material was replaced with clean sand.

Six piles were driven (four 324 mm dia., 9.5 mm wall thickness; one 324 mm dia., 11.5 mm thickness, one 915 mm dia., 19 mm thickness) at the site. The relative embedments of the five smaller piles and the larger pile are shown in Fig. 9. The five smaller piles were placed and tested under the supervision of University of British Columbia (UBC) personnel. The large pile was placed and tested under the supervision of the B.C. Ministry of Transportation and Highways (M.O.T.H.).

Axial Pile Load Tests

The "Quick Load Test Method" of axial loading (similar to ASTM D1143-81 Section 5.6) was used with the axial load being applied in roughly 5% increments of the anticipated failure load for the piles shown in Fig. 9. The 'Quick Load Test Method' was used to minimize time-dependent effects.

Analysis of the results from axially loaded vertical test piles is more complicated than generally realized (Brierley et al, 1978). For a pile (generally assumed to be stronger than the soil), the ultimate failure load is reached when the pile plunges; i.e., rapid settlement occurs under sustained or only slightly increased load. This definition, however, is inadequate because plunging requires very large displacements and it is often

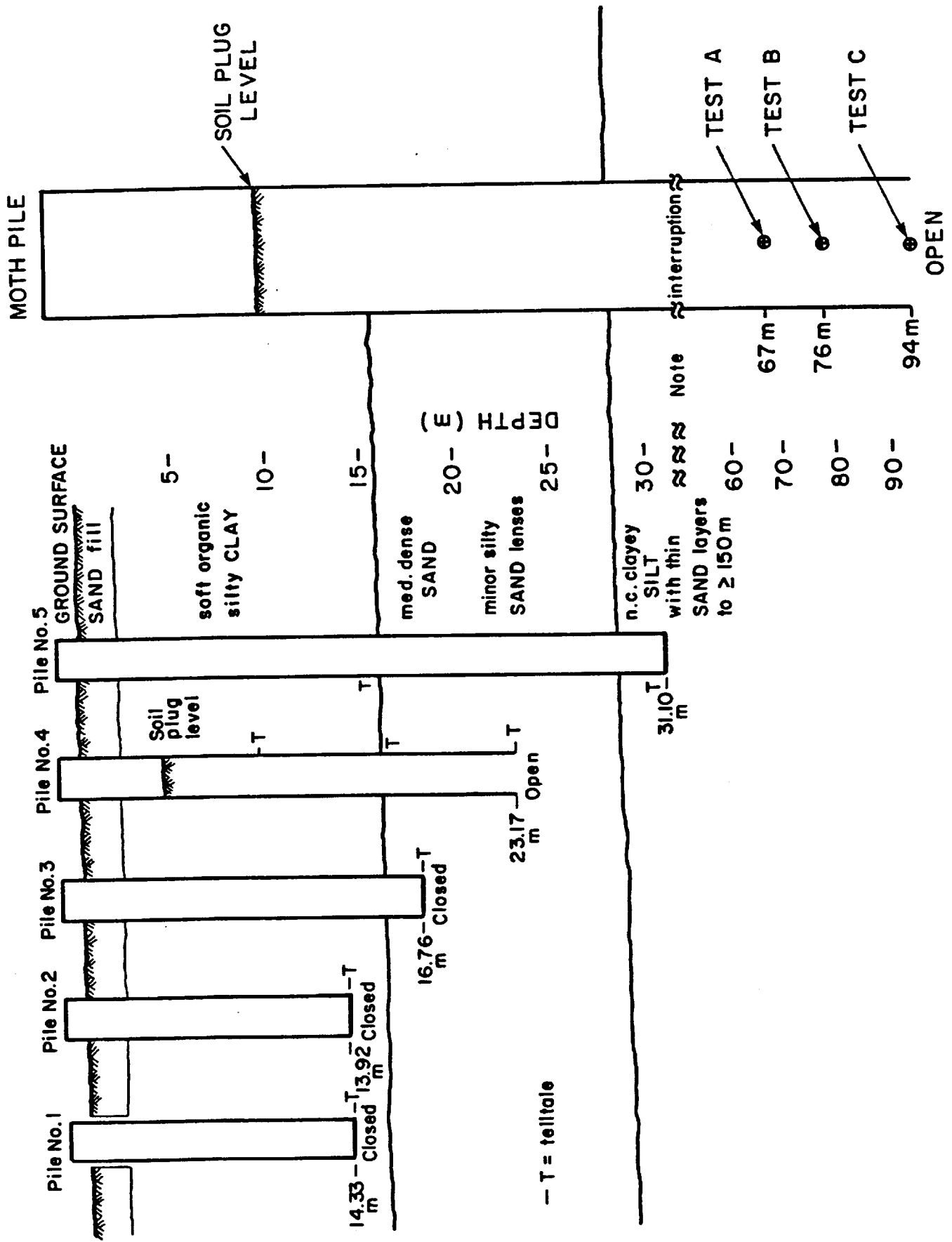

Fig. 9. Relative Embedments of Test Piles

less a function of the pile-soil system and more a function of the capacity of the man-pump system (Fellenius, 1980). To be useful, a failure definition should be based on a simple mathematical rule that can generate repeatable results independent of the individual using the method and of the scale chosen for plotting the load test data. For example, in Fig. 10, depending upon the scale chosen, the hypothetical test pile could be seen as a predominantly friction or 'floating' pile (upper figure) or a predominantly end bearing pile (lower figure). The method recommended by the Canadian Foundation Engineering Manual (1985, Part 3, Subsection 22.5.1) is that by Davisson (1973). This method involves a simple graphical manipulation of the theoretical elastic compression line for the pile in question. Davisson's method is what has been used in this study to determine failure loads. Fellenius (1980) studied nine commonly used failure criteria and found Davisson's method to be among the most conservative.

Fig. 11 presents a summary of the load test results for the five smaller piles. Also included in Fig. 11 is a summary of the three tests on the larger pile. The larger pile was tested at three depths (67, 78 and 94 m) as shown in Fig. 9. The reduction in measured load observed for the larger pile occurred because, with rapid axial deflections, the hydraulic jacks were unable to sustain the load.

Prediction of Axial Pile Capacity

The prediction methods will be separated into two sections as follows:

- 1) direct static prediction methods
- 2) indirect static prediction methods.

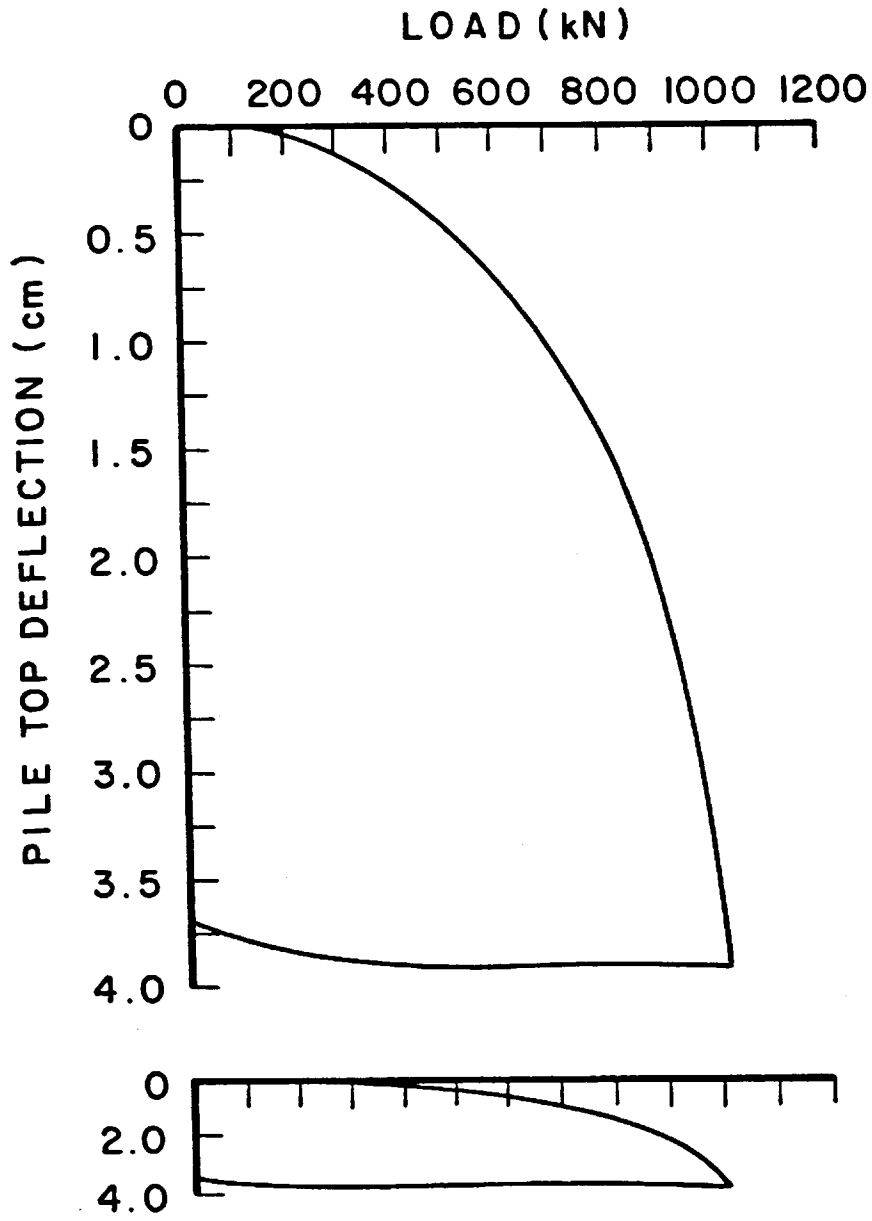
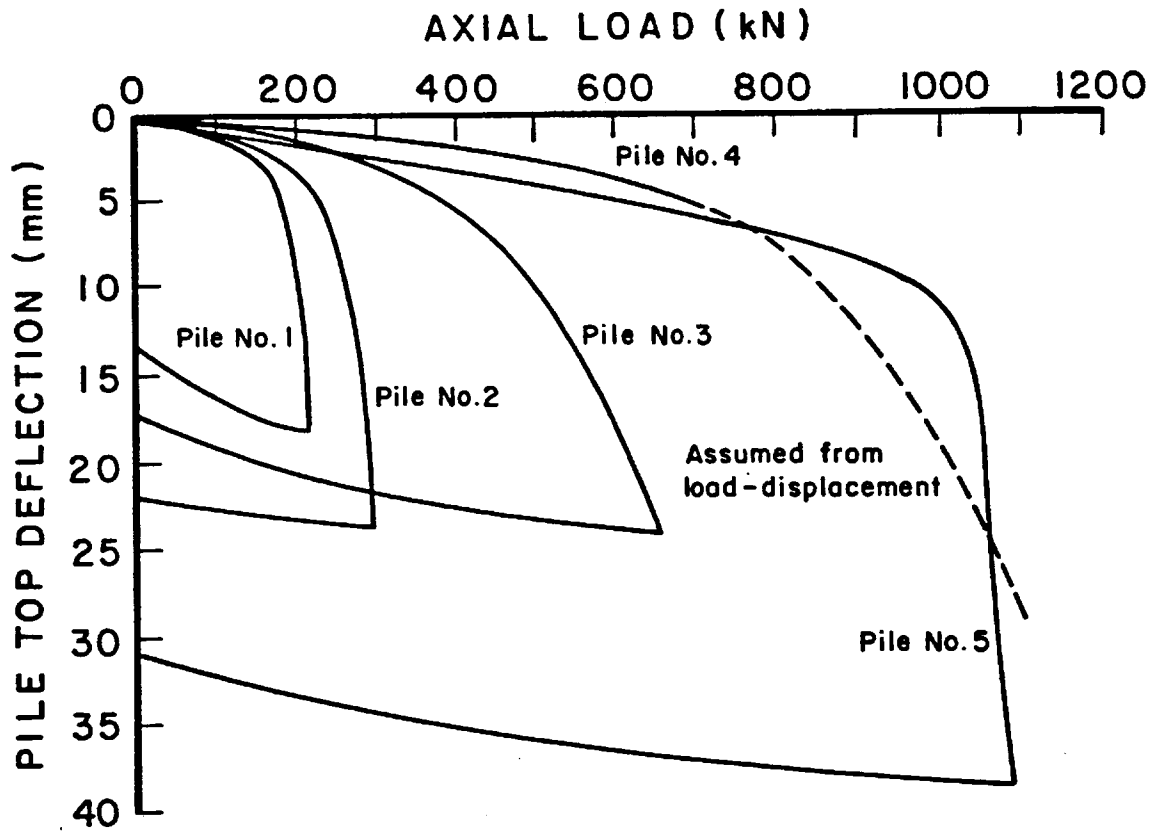
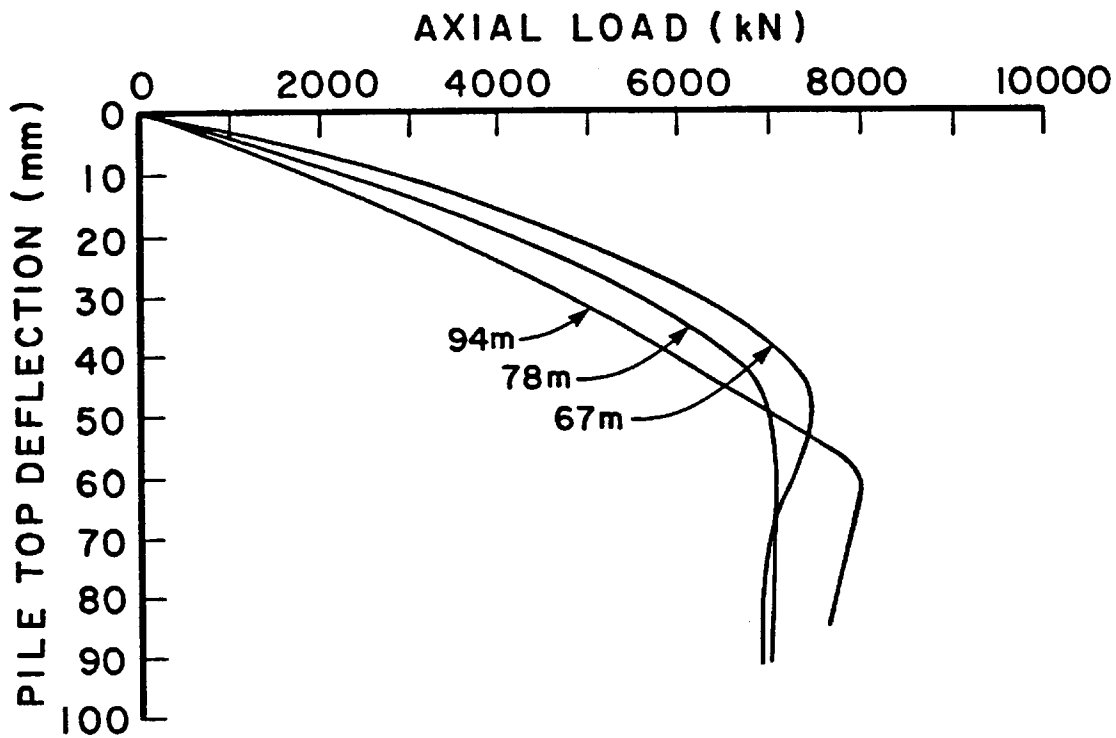

Fig. 10. Load-Displacement Diagram of a Hypothetical Test Pile Drawn to Two Different Scales



(a) UBC PILE RESEARCH SITE
AXIAL LOAD TEST RESULTS



(b) MOTH PILE RESEARCH SITE

Fig. 11. Summary of Load Test Results

The term "direct method" is used for any static prediction method that uses CPT data directly by the use of theoretical and/or empirical scaling factors without the need to evaluate any intermediate values (coefficients of earth pressure, bearing capacity factors, friction angle, etc.). The scaling factors, in all cases, resemble the original work of de Beer (1963). As shown in Fig. 12, if a probe of zero diameter penetrates into a soil layer, the penetration resistance would follow the idealized curve ABCD. This is to say that the device would "feel" the entire effect of the lower soil layer immediately upon penetration. However, if a large diameter pile were pushed into the layer, the point resistance would not equal that of the zero diameter probe until the pile reached a greater depth, E. This depth, E, is termed the critical depth (D_c). De Beer showed that it is reasonable to assume that the pile resistance curve between points B and E varies linearly; thus, the pile resistance at any intermediate depth could be determined if the idealized penetration resistance curve and D_c were known. Although it is not possible to use a probe of zero diameter, the standard sized electric cones (3.57 cm in diameter) come close to meeting this condition (curve ABC'D) and the cone penetration resistance curve is a reasonable approximation of the idealized curve. Meyerhof (1951), de Beer (1963), and others have shown that D_c is a function of foundation size; therefore, it is more logical to express critical depth as a ratio $(D/B)_c$ where B is the foundation diameter. This entire concept is complicated in highly layered materials where layer thicknesses are less than that of D_c for the large diameter pile. In these situations the full resistance may be mobilized on the cone but it will not be realized for the pile before another layer is penetrated. The way in which the different direct methods define the critical depth and layering effects for both sleeve friction and point resistance is, for the most part, what separates the methods available.

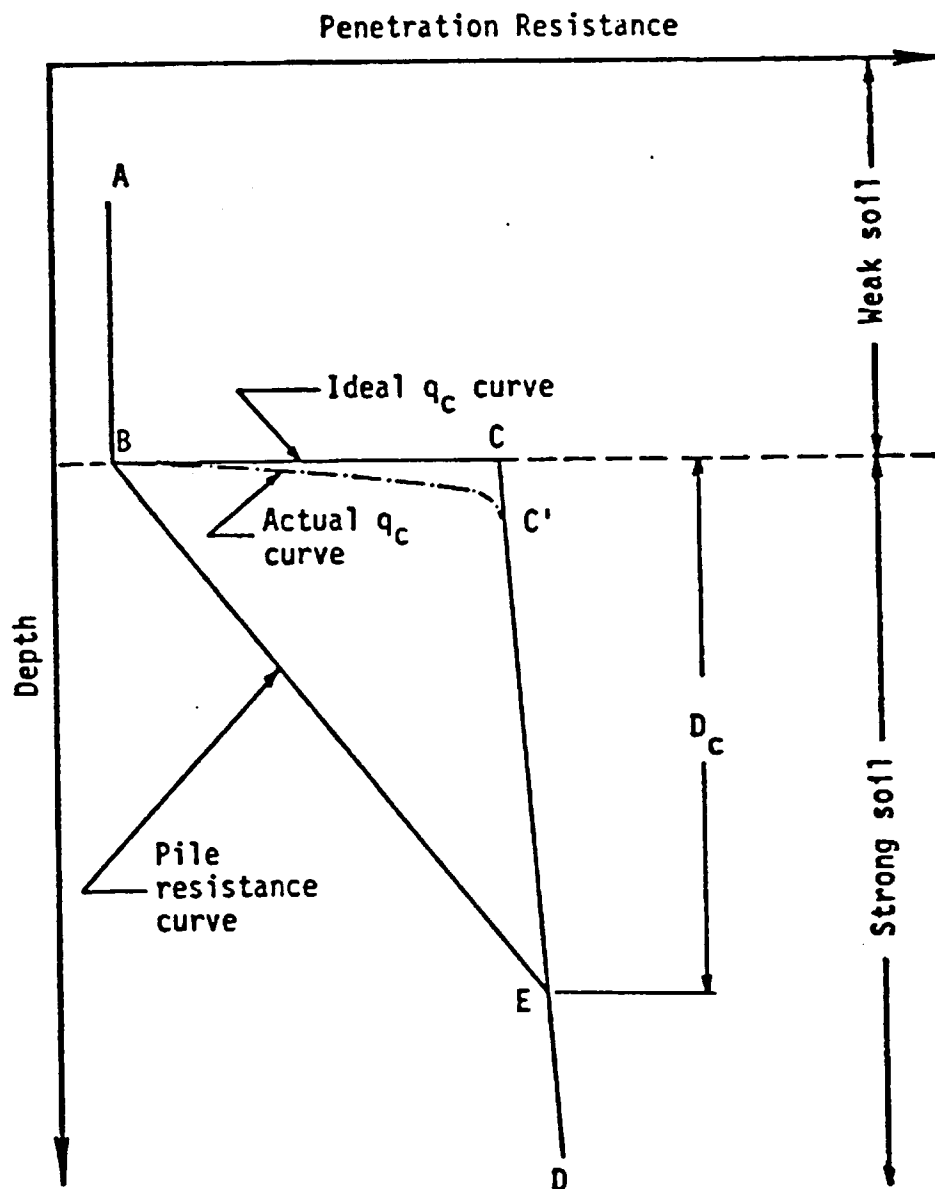

Fig. 12. de Beer Scale Effect Diagram for CPT
Pile Capacity Predictions
(Adapted from Nottingham, 1975)

An "indirect method" is taken to refer to static prediction methods that require intermediate correlations in order to predict pile capacity from CPT data. It must be realized that, unlike the direct methods, indirect methods were not formulated specifically for use with CPT data. As such, any discrepancies between the predicted versus measured pile capacity using the indirect methods may not be due solely to problems inherent to these methods.

Table 1 lists the thirteen methods investigated. The first five methods are direct methods whereas the remaining eight are indirect methods.

Table 1 - Prediction Methods

Method	References	Notes
1. Schmertmann and Nottingham CPT	Schmertmann (1978)	Proven CPT Method
2. de Ruiter and Beringen CPT	de Ruiter and Beringen (1979)	European (Fugro)
3. Zhou et al CPT	Zhou et al (1982)	Chinese Railway Experience
4. Van Mierlo and Koppejan CPT	Van Mierlo and Koppejan (1952)	Original Dutch
5. Laboratoire Central des Ponts et Chaussées CPT	LCPC-Bustamante and Giancesalli (1982)	French Method
6. API RP2A	American Pet. Inst. (1980)	Offshore
7. Dennis and Olson	Dennis and Olson (1983a & b)	Modified API
8. Vijayvergiya and Focht	Vijayvergiya and Focht (1972)	"λ" Method
9. Burland	Burland (1983)	"β" Method
10. Janbu	Janbu (1976)	NIT
11. Meyerhof Conventional	Meyerhof (1976)	Original Bearing Theory
12. Flaate and Selnes	Flaate and Selnes (1977)	NGI
13. Broug	Broug (1982)	$q_c = f(f_s)$ etc.

Comprehensive plots of the direct and indirect methods found to supply the best results are shown in Figs. 13 and 14 respectively. Fig. 13 shows the LCPC CPT method and Fig. 14 shows the Dennis and Olson method. Note how well the LCPC method predicts the capacity of both the smaller piles and the tests on the larger pile. The Dennis and Olson method predicts the capacities of the smaller piles quite well but significantly underpredicts the capacities of the tests on the larger pile. This trend is seen for all of the indirect methods investigated.

Fig. 15 summarizes the results of all the methods in the form of bar charts. Note that both the direct and indirect methods did a reasonable job of predicting the measured capacities of the smaller piles. The direct methods, the Zhou et al method to a lesser extent, also all predicted the tests on the larger pile quite satisfactorily. However, without exception, the indirect methods had predictions that were significantly in error and non-conservative when compared to the measured results for the large pile. Since the indirect methods generally did so well in predicting the capacity of the smaller piles, it suggests that (since the piles are all in the same soil deposit) scale effects are extremely important. Most of the indirect methods are empirical in nature and based upon observed results from piles much smaller than 915 mm in diameter and nearly 100 m in length.

Lateral Pile Load Tests

Unlike with the axial load case, no standard method of interpreting lateral load test results exists. The effects of creep (time effects) can be very pronounced during lateral pile testing. Until standardization of testing is realized, it will remain difficult to compare results between researchers.

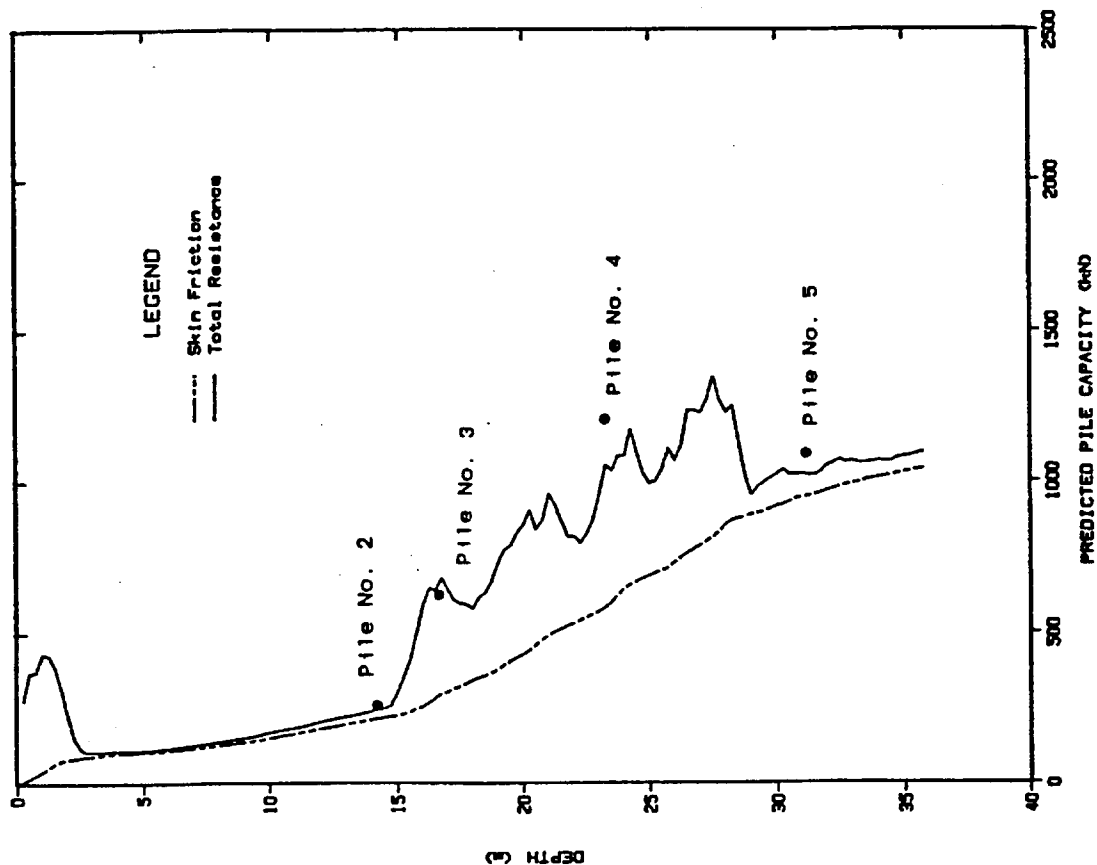
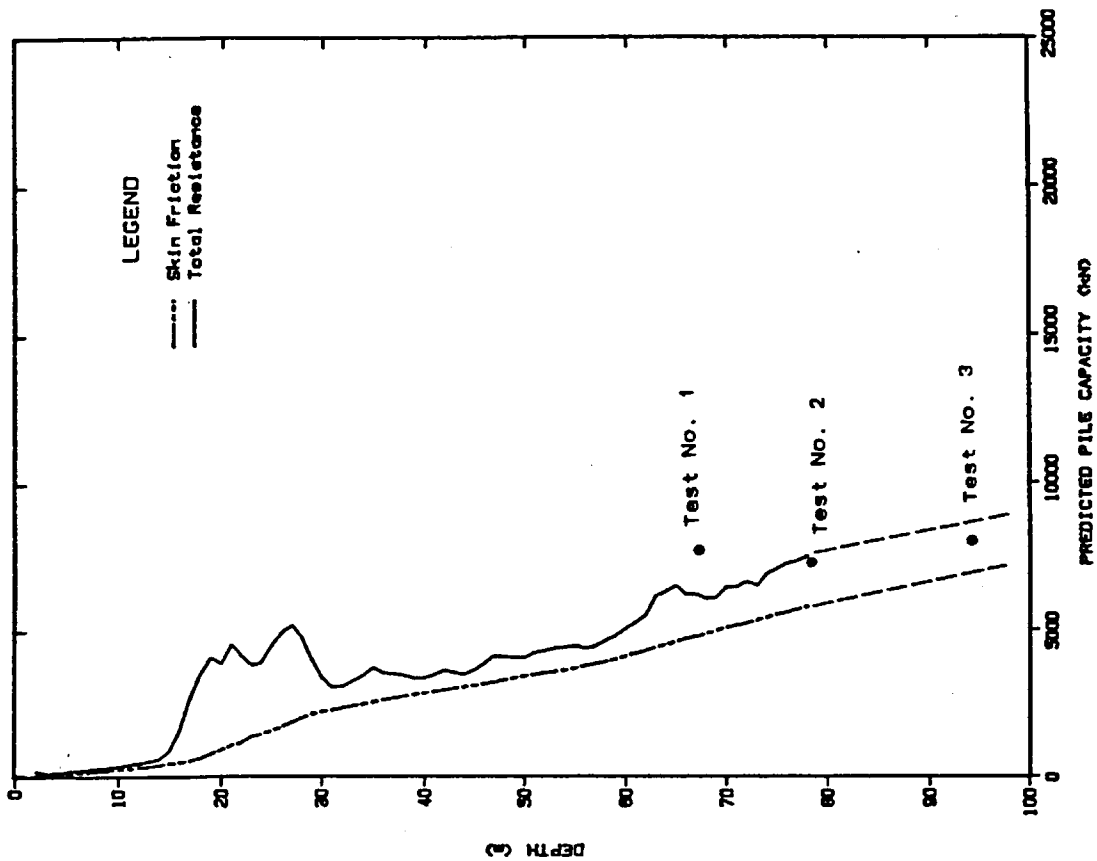

Fig. 13. Predicted Versus Measured Axial Pile Capacity:
LCPC CPT Method

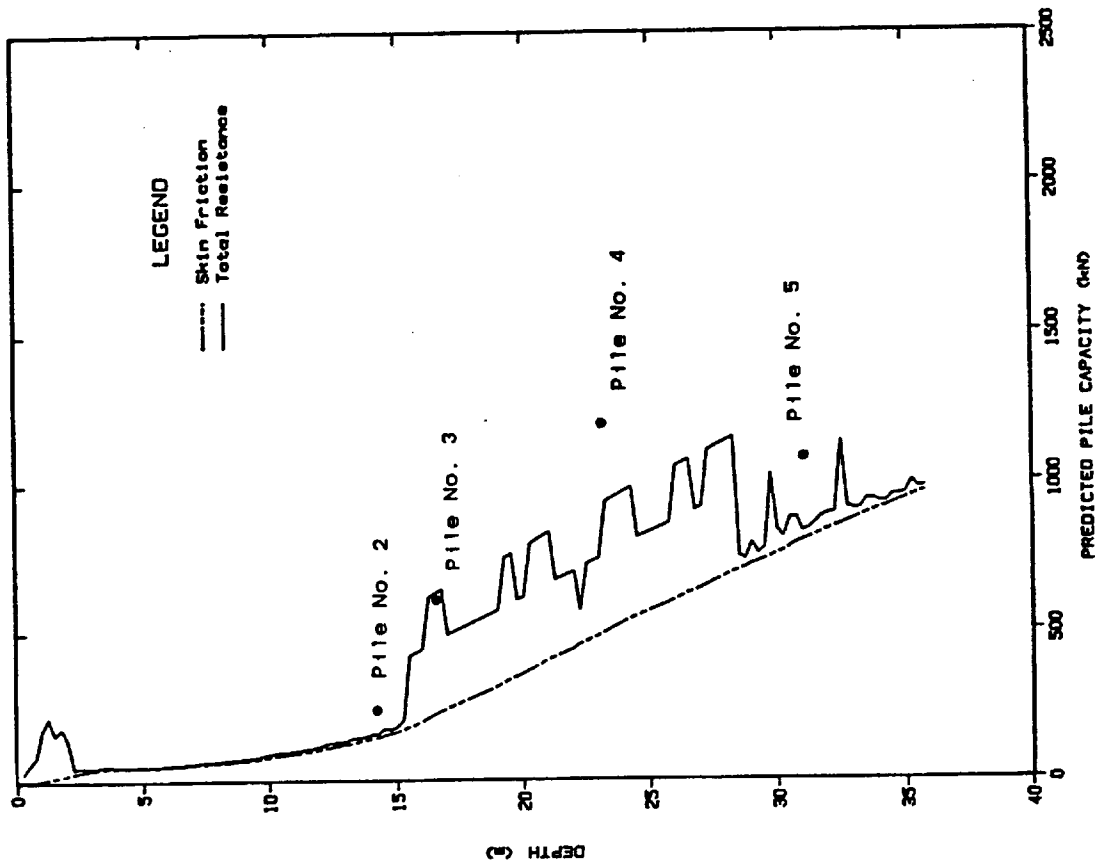
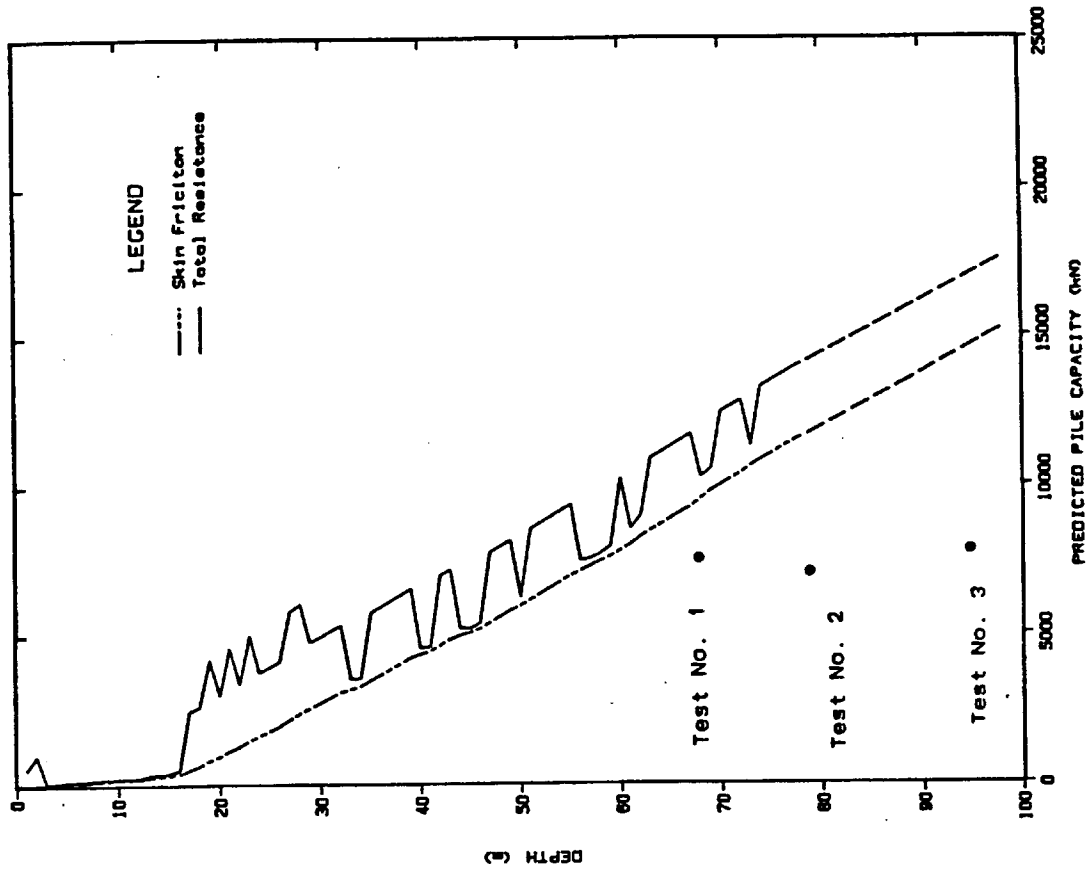

Fig. 14. Predicted Versus Measured Axial Pile Capacity:
Dennis and Olson Method

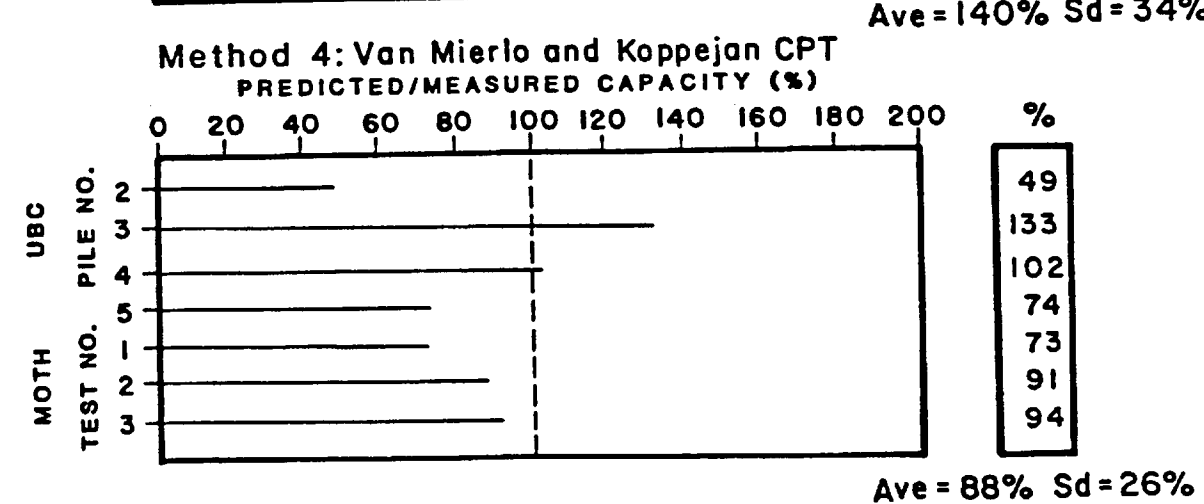
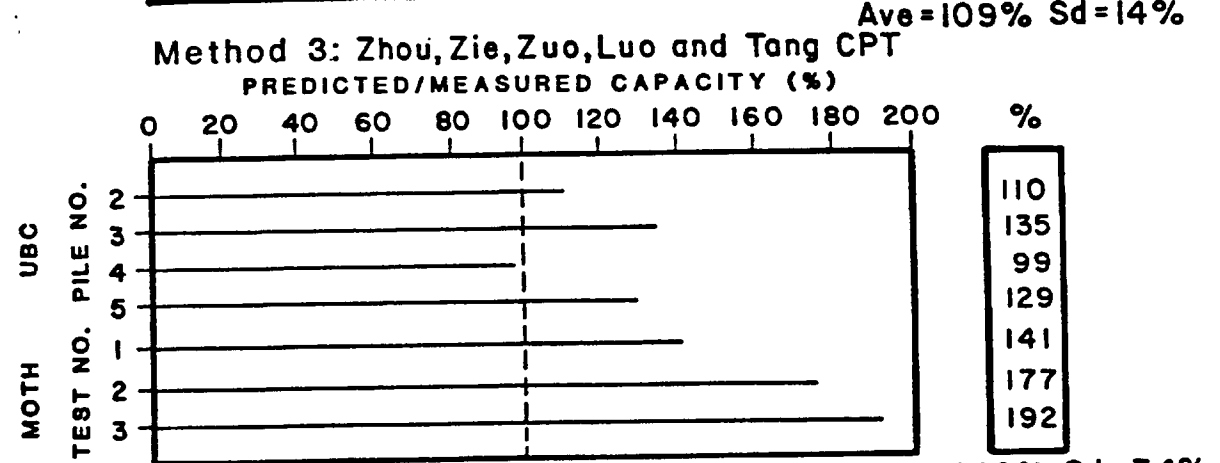
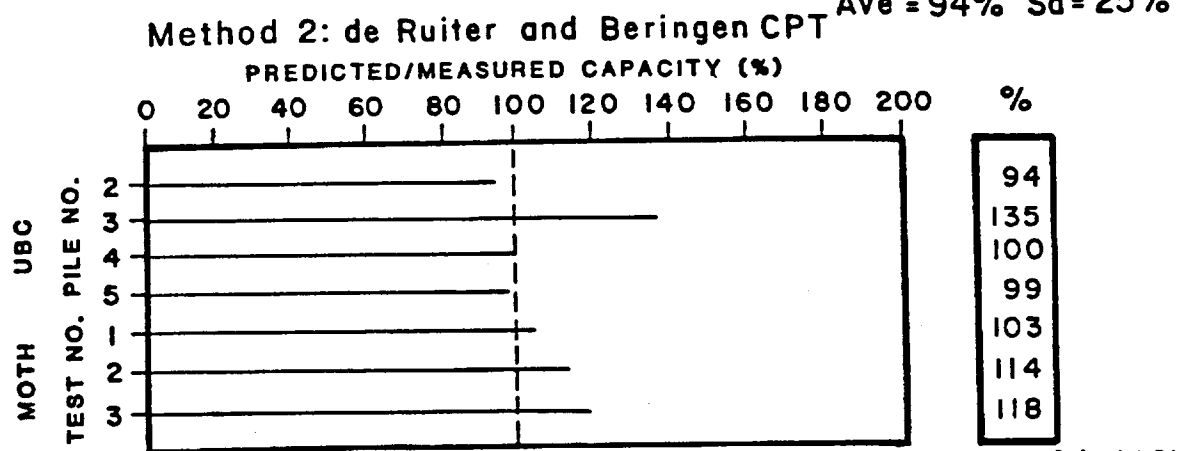
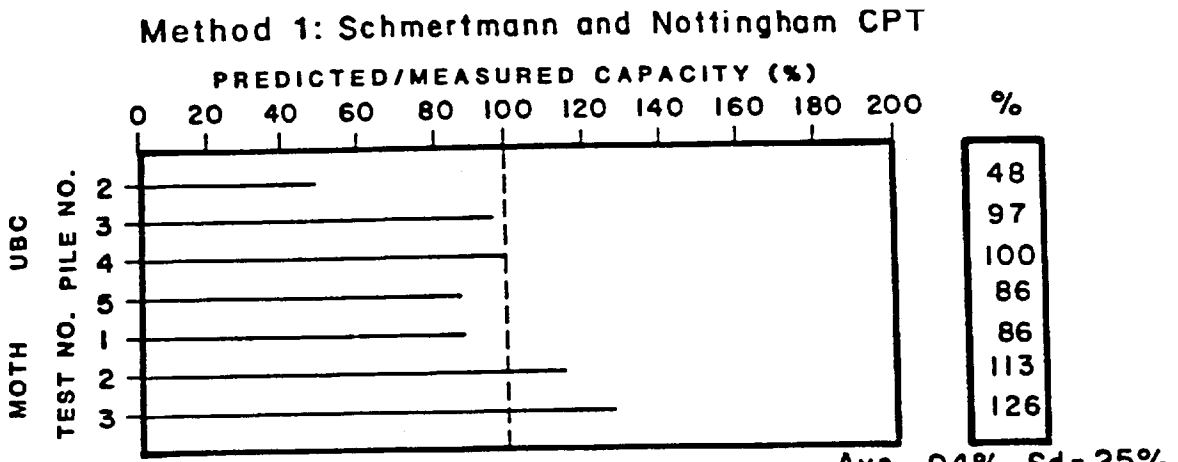
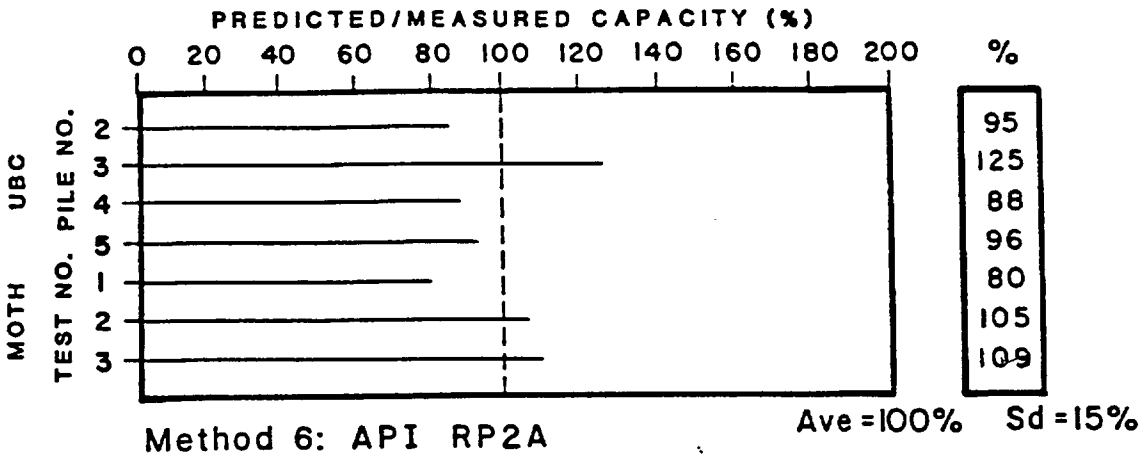
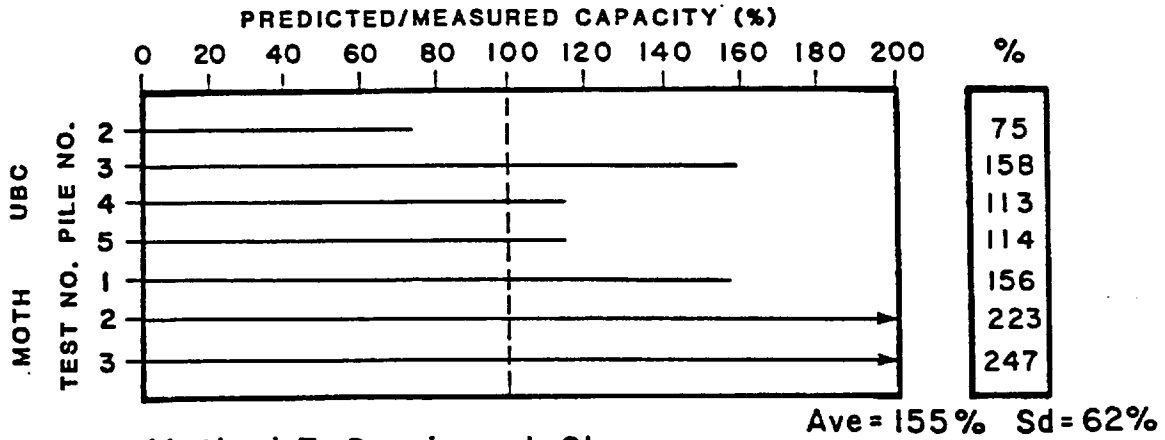

Fig. 15. Summary of Predicted Versus Measured Axial Pile Capacity

Method 5: LCPC CPT



Method 6: API RP2A



Method 7: Dennis and Olson

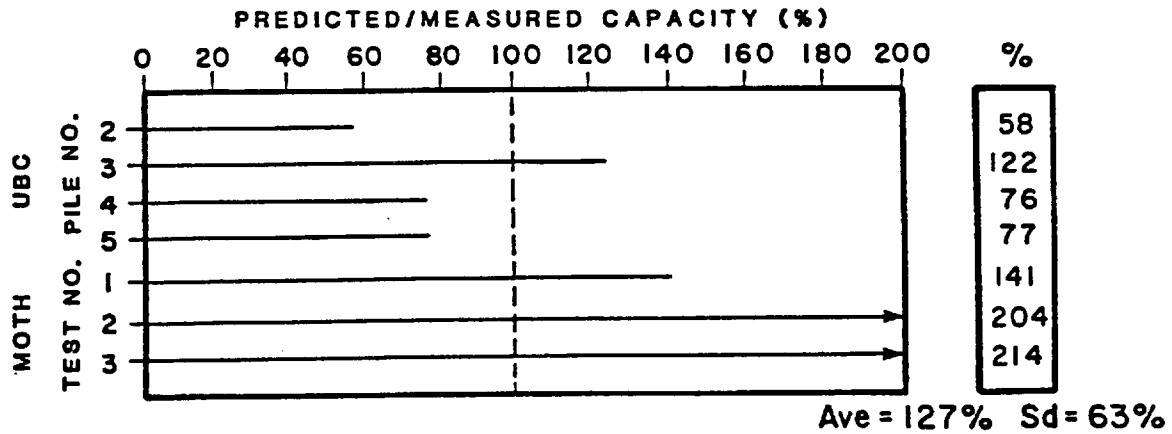

Method 8: Vijayvergiya and Focht

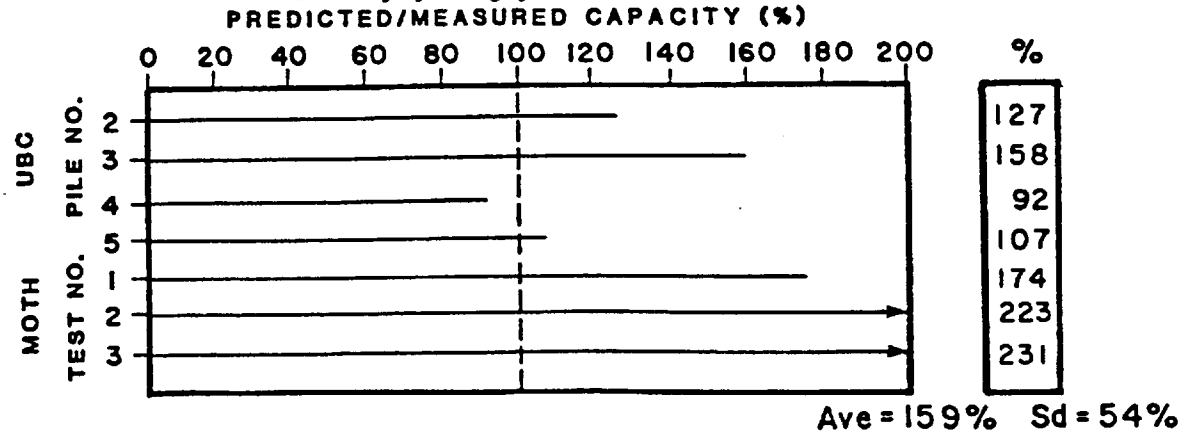
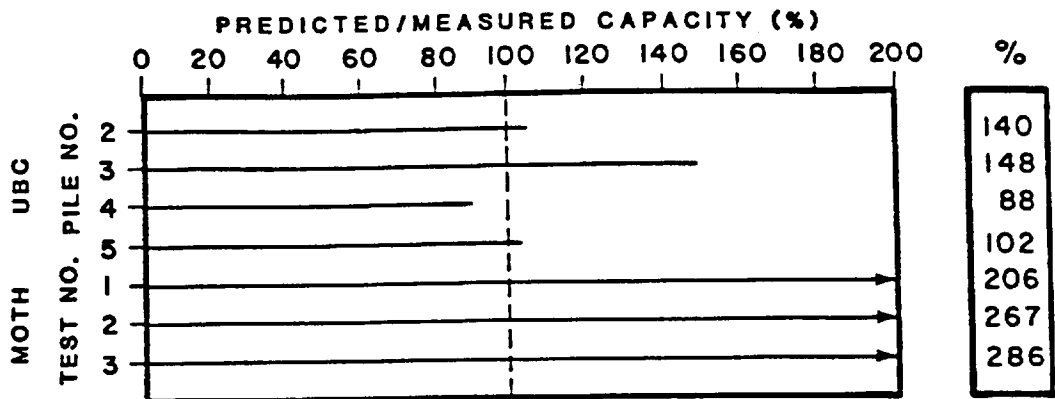

Fig. 15. Continued...

Method 9: Burland



Ave = 172% Sd = 82%

Method 10: Janbu

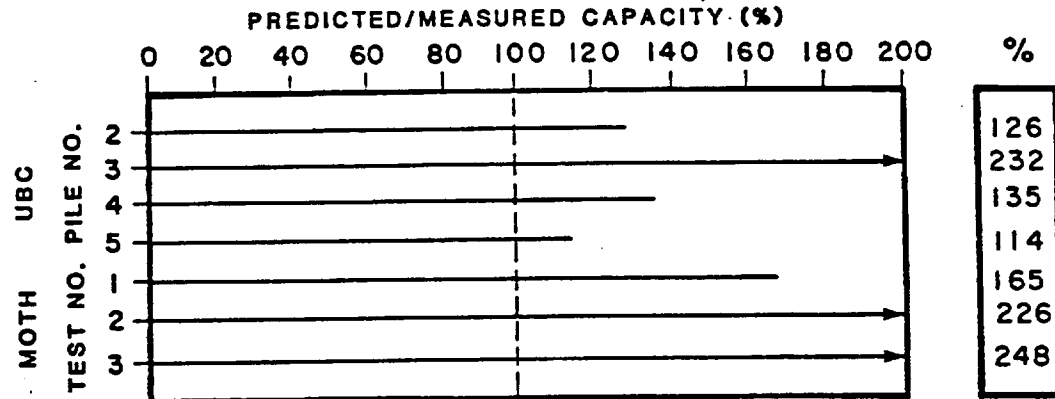

Ave = 178% Sd = 56%

Method 11: Meyerhof Conventional

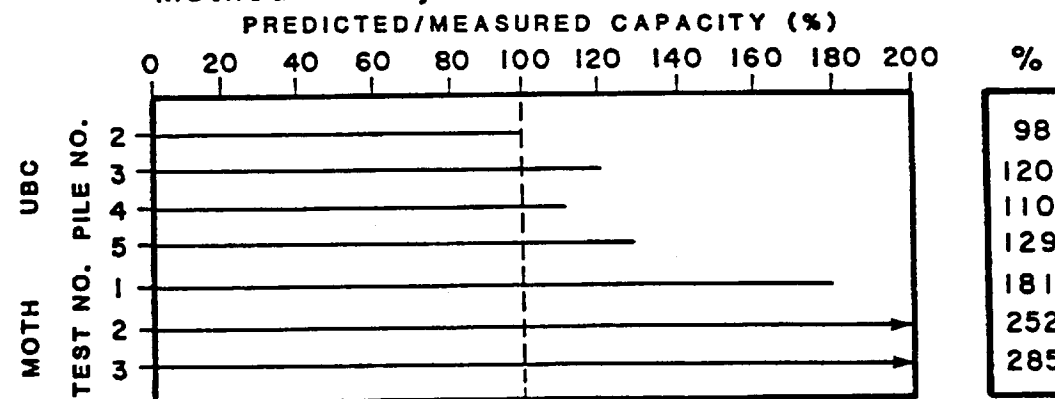

Ave = 168% Sd = 74%

Method 12: Flaate and Selnes

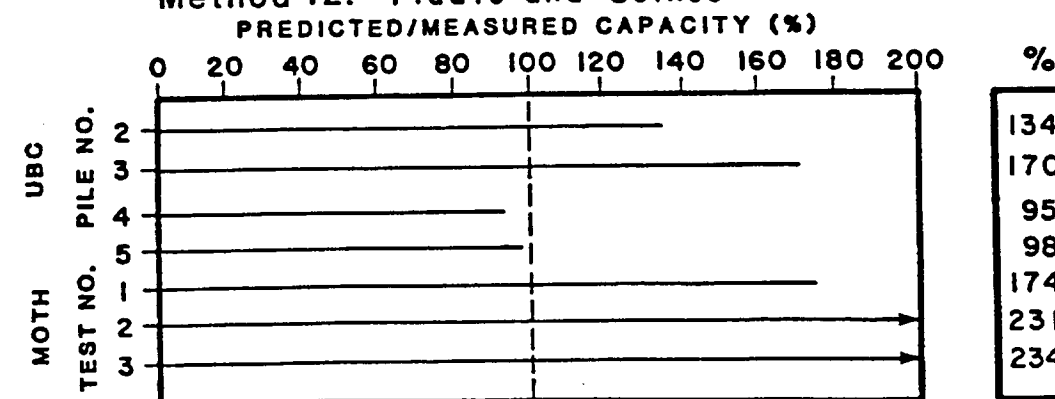

Ave = 162% Sd = 57%

Fig. 15. Continued...

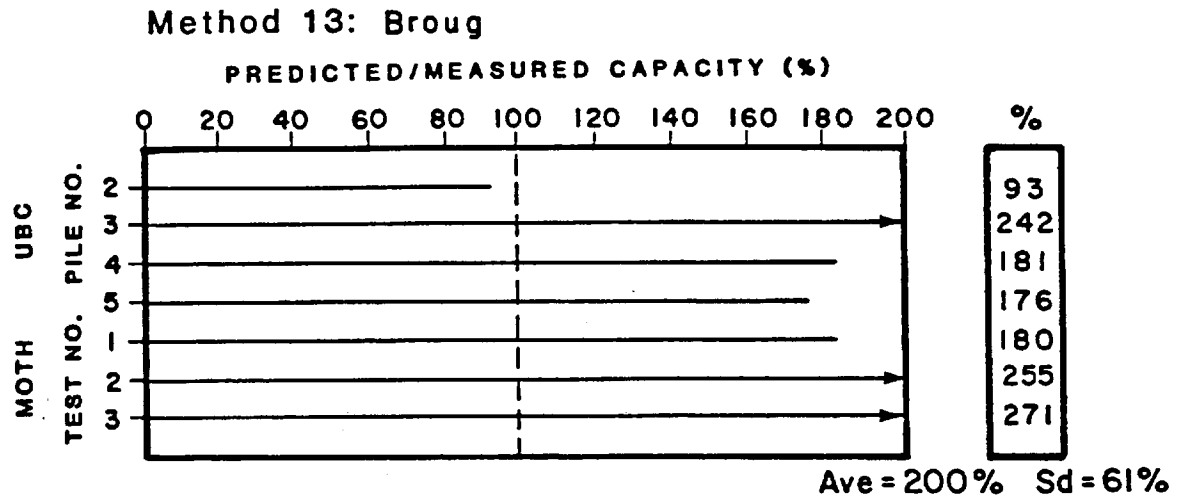

Fig. 15. Continued.

For both the smaller piles and the larger pile, the lateral load tests were performed by jacking between two piles. The pile top deflections were obtained by dial gauge installations, whereas the deflected shape profiles were obtained using inclinometer readings. The lateral loads were applied and then held for approximately 15 minutes to allow time for readings to be taken.

Prediction of Lateral Pile Behaviour

The non-linear subgrade reaction method is widely used for the design of laterally loaded piles. This method replaces the soil reaction with a series of independent Winkler springs. The non-linear behaviour of the soil springs is represented by P-y (load, deflection) curves which relate soil reaction and pile deflection at points along the pile lengths. P-y curves are commonly obtained using empirical relationships and laboratory data. This laboratory data, however, may not accurately reflect the true in-situ behaviour of the soil.

In order to analyze the pile behaviour using these P-y curves, a finite difference program is used (Reese, 1980).

For this study two methods of predicting P-y curves in order to evaluate lateral behaviour are presented. One of these methods uses in-situ test data from the full-displacement pressuremeter test and the other uses data from the flat plate dilatometer test.

Full Displacement Pressuremeter P-y Method

The method of using the full displacement pressuremeter test (FDPMT) to obtain P-y curves is described fully by Robertson et al (1986). The method is summarized in Fig. 16 and involves three steps:

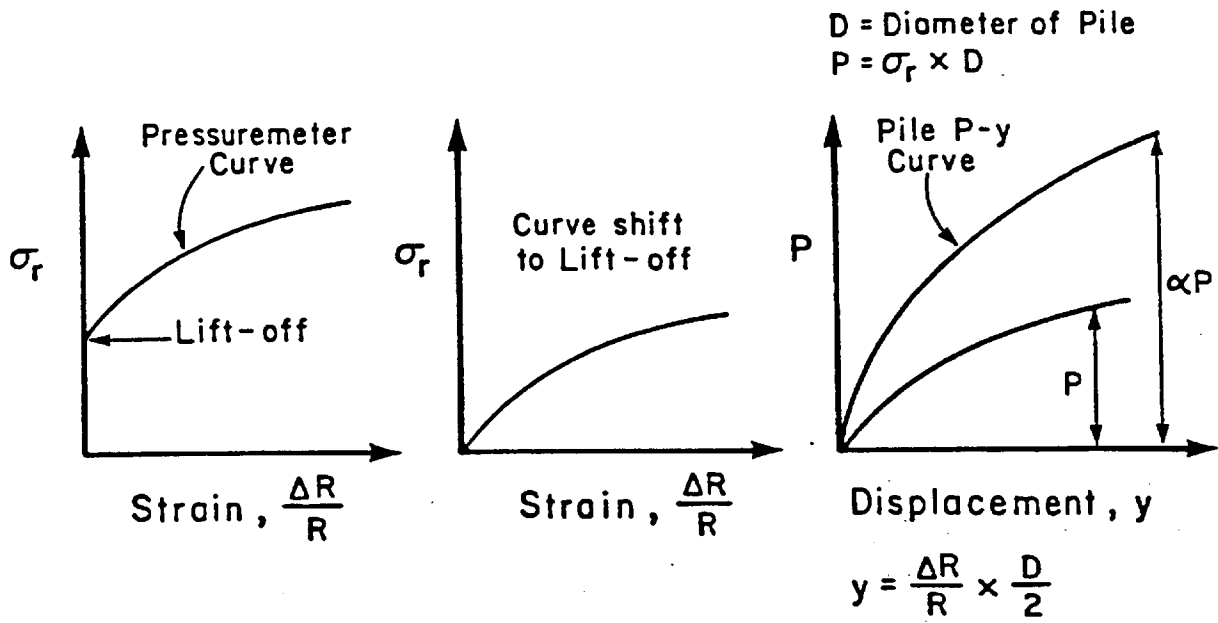

Fig. 16. Schematic Representation of Development of Pile P-y Curves from Pressuremeter Curves (After Robertson et al., 1986)

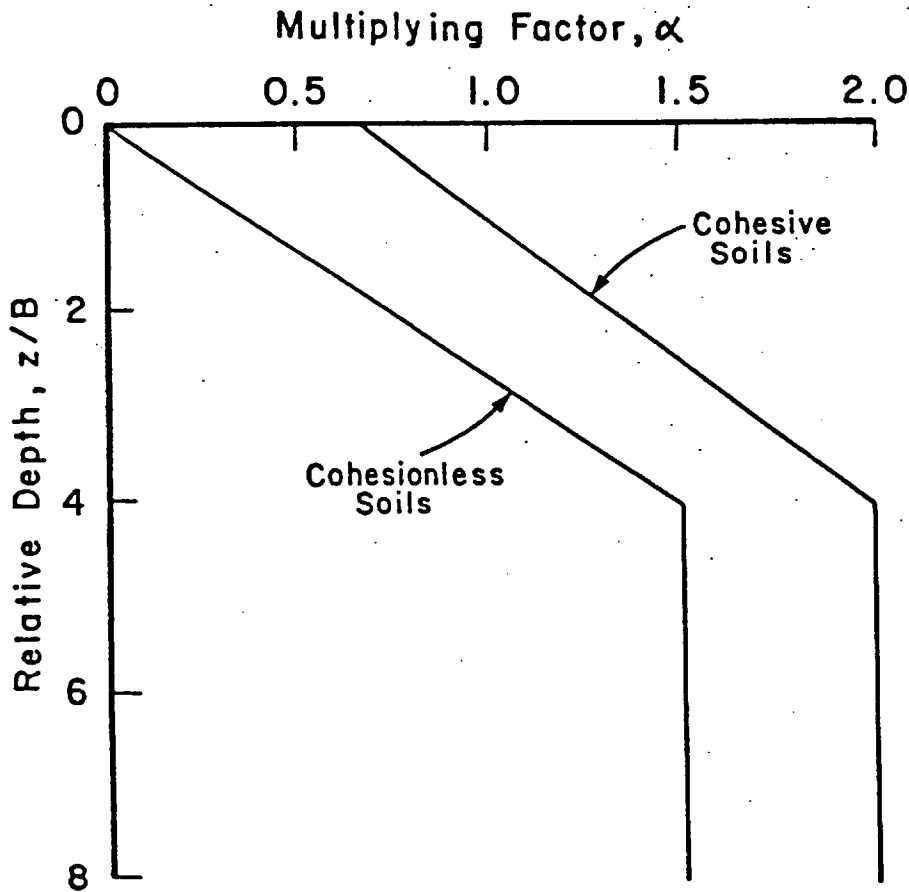

Fig. 17. Variation of Multiplying Factor with Relative Depth (After Robertson et al., 1986)

- 1) The pressuremeter curve is shifted down so that the lift-off point is at the origin. When a pile is installed prior to a lateral load test, the vector sum of the lateral soil pressure is zero. During a pressuremeter test, the membrane of the pressuremeter must expand radially and overcome the lateral soil pressure. Thus, to accurately model a pile, the lift-off pressure must be subtracted from the pressuremeter curve.
- 2) The pressuremeter curve must be scaled to the units of a P-y curve. The vertical axis is adjusted simply by multiplying by the pile diameter, D ($\sigma_r \cdot D = P$) while the horizontal axis is multiplied by the pile radius, $D/2$ ($\Delta R/R \cdot D/2 = y$).
- 3) Finally, the resulting P-y curve must be adjusted by an empirical soil multiplication factor, α , to reflect the difference in force required to expand a pressuremeter membrane or to deflect a pile laterally. The variation of α with soil type and depth is shown in Fig. 17.

The results of computed versus measured pile behaviour using the FDPMT method are shown in Figs. 18 and 19. In Fig. 18, the larger pile's deflection at ground surface and deflected shape versus depth profile both show very good agreement between measured and predicted behaviour. The predicted deflection at the pile head is within 20% of the measured values. Any discrepancy in prediction is shown as being conservative in nature. For the smaller piles, Fig. 19 shows that good agreement is again evident with the predictions of pile head deflection being within 30% of the measured values. For both the small and large piles, the predicted versus measured depths of contraflexure agree very well.

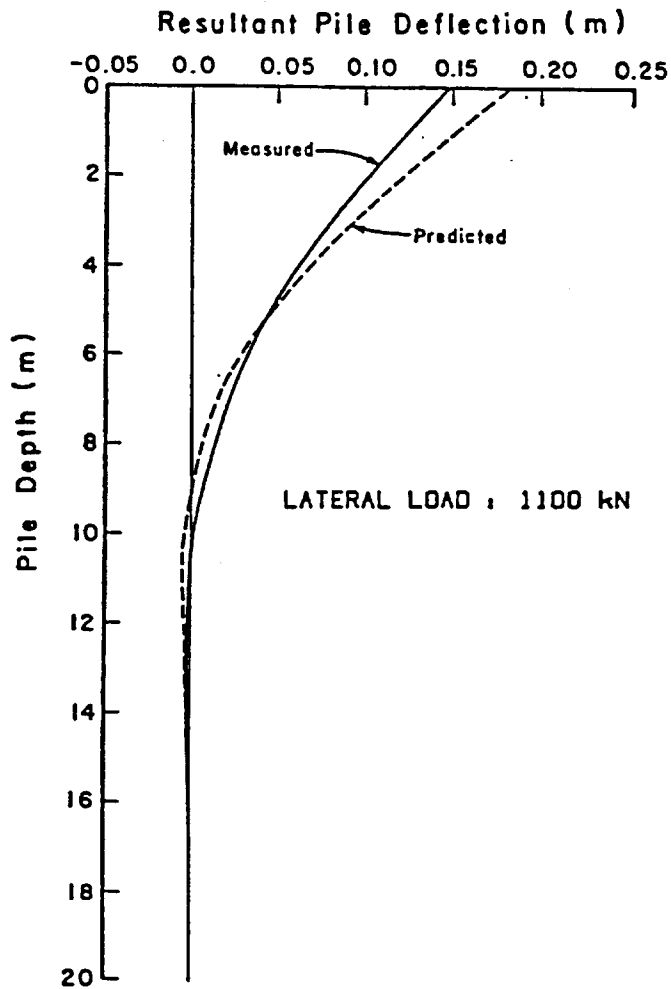
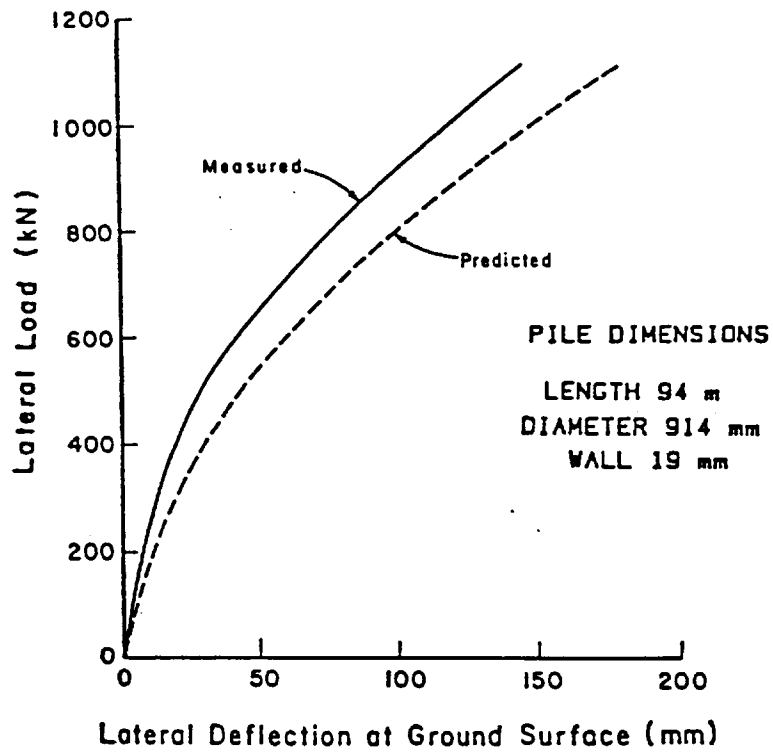

Fig. 18. Predicted Versus Measured Lateral Pile Behaviour:
 MOTH Test Pile Using FDPMT

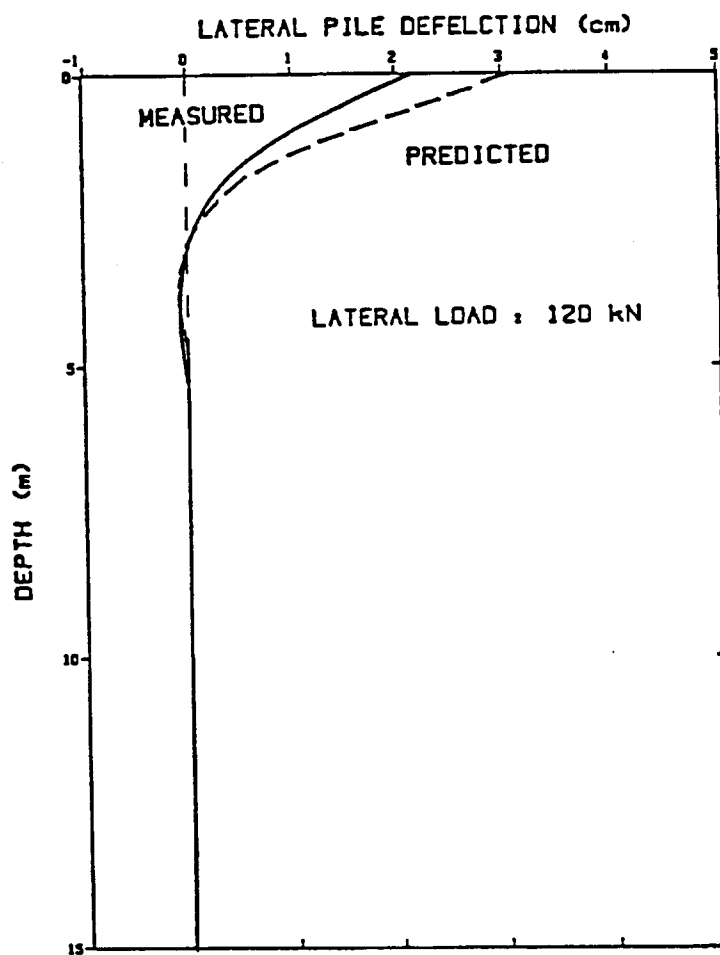
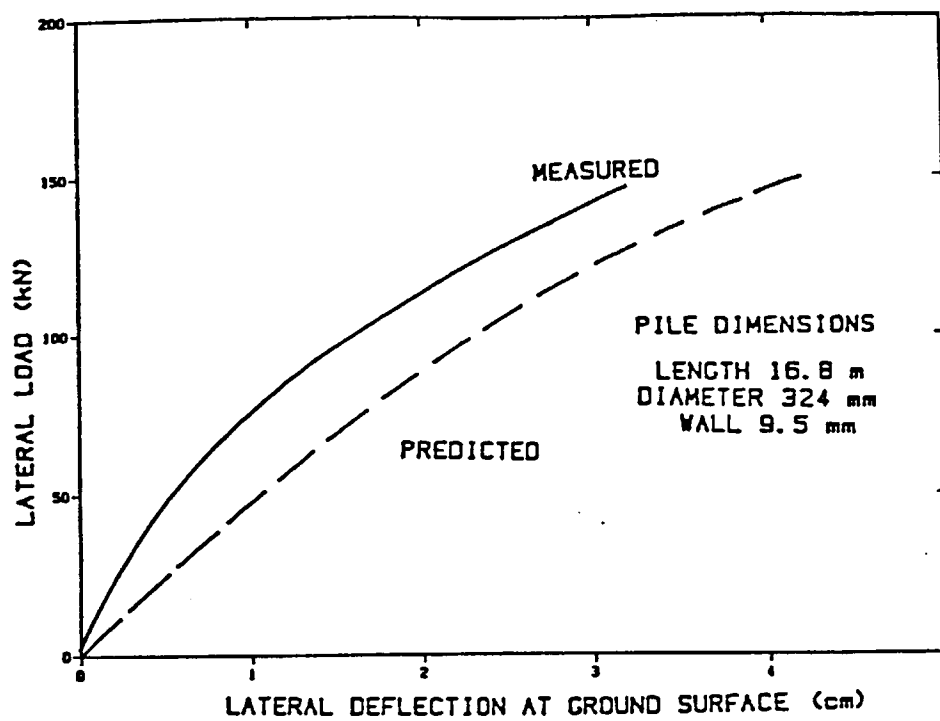

Fig. 19. Predicted Versus Measured Lateral Pile Behaviour:
 UBC Pile Research Site Using FDPMT

Flat Plate Dilatometer P-y Method

The method of using the flat plate dilatometer test (DMT) to obtain P-y curves is described fully by Robertson et al (1987). Fig. 20 shows a flow-chart which describes the method; six steps are seen as necessary:

- 1) obtain field DMT data
- 2) use DMT interpretaton program to generate soil parameters (strength, modulus, etc.)
- 3) calculate P_u (ultimate soil resistance) and y_c (critical deflection) at each test depth
- 4) in order to use the finite difference program, LATPILE, which can handle 20 input P-y curves, the near continuous record of P_u and y_c must be averaged into a maximum of 20 corresponding layers.
- 5) now generate P-y curves using the concept of the cubic parabola (Matlock, 1970) as shown in Fig. 21.
- 6) now run LATPILE to produce the predicted lateral pile behaviour results.

The results in Fig. 22 for the larger pile (915 mm dia.) show that the predicted deflection agrees well with the measured deflection. The predicted deflection is approximately 25% larger than the measured deflection at the pile head under large load (1100 kN) and agreement is closer at lower loads. The deflected shape versus depth profiles at a load of 1100 kN agree closely with the points of contraflexure both occurring at about 11 m depth.

The results in Fig. 23 for the smaller piles (324 mm dia.) again shows good agreement between predicted and measured deflection. The difference between the predicted and measured results is never more than approximately

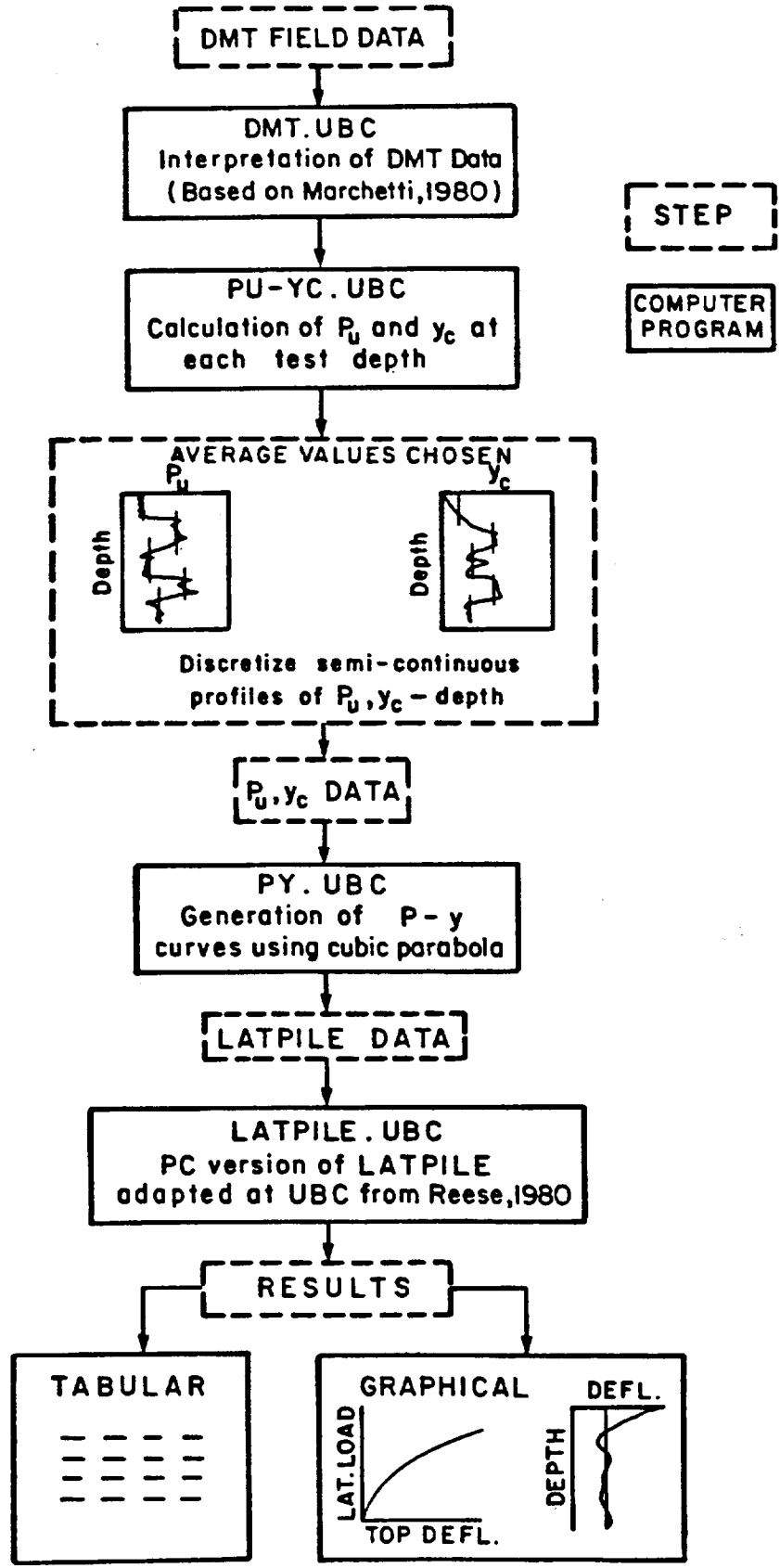

Fig. 20. Flowchart for Determining P-y Curves from DMT Data

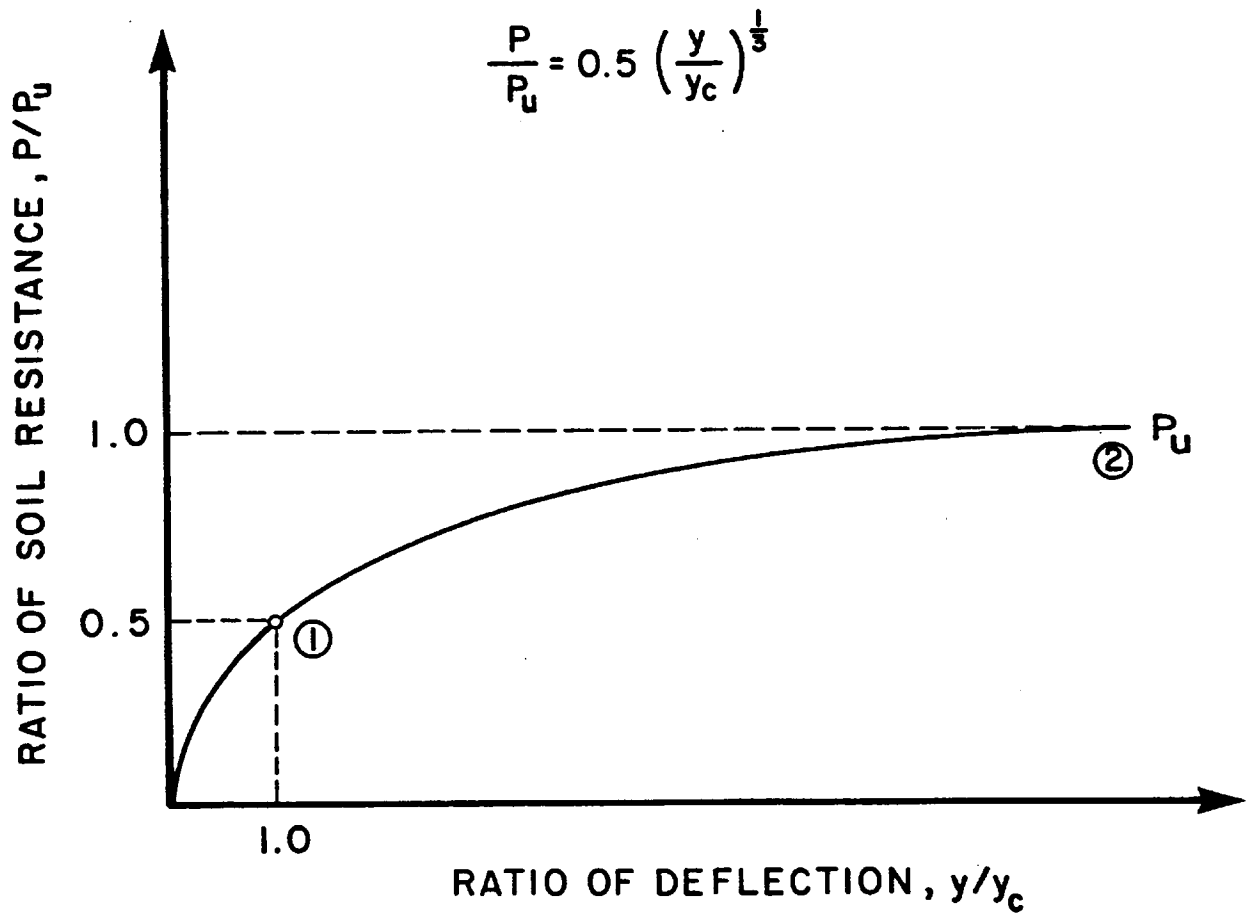

Fig. 21. Cubic Parabolic P-y Curve for Strain Hardening
(Adapted from Matlock, 1970)

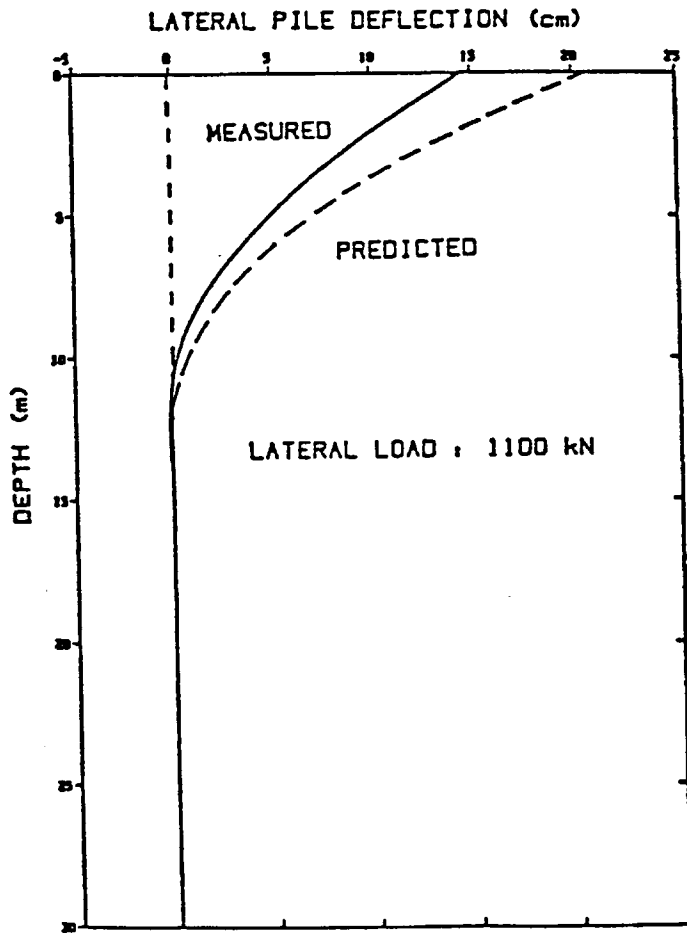
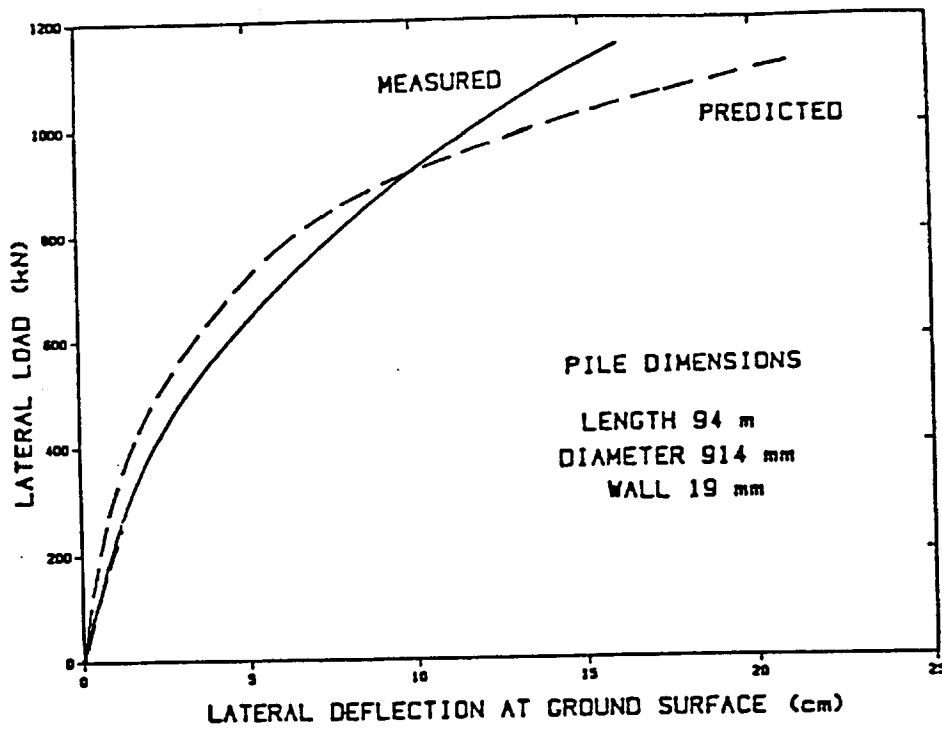

Fig. 22. Predicted Versus Measured Lateral Pile Behaviour:
 MOTH Test Pile Using DMT

25% for the entire range of loads with the predicted values being higher. The deflected shape versus depth profile for 120 kN load are of similar good agreement.

The DMT, being a new method, needs further validation and hence this method must be used with caution.

Summary and Conclusions

This paper briefly summarizes the use of in-situ testing methods for deep foundation design in deltaic soils. In-situ testing methods are rapid procedures which supply comprehensive and repeatable data representative of the actual subsurface conditions. The cone penetration test, which can be considered to be a model displacement pile, can provide excellent predictions of axial pile capacity. Both the full-displacement (or cone) pressuremeter and the flat plate dilatometer are seen as useful tools for assessing laterally loaded pile behaviour. The dilatometer method, however, requires considerably more validation.

For a large project, where many piles are to be required, the use of in-situ tests can be highly economical while providing extensive information. By calibrating, for example, the CPT to one full-scale pile load test at a site, the rest of the site may be rapidly covered by cone soundings. This will allow excellent control of pile capacities as any heterogeneous subsurface conditions will be readily identified.

Acknowledgments

The assistance of the Natural Sciences and Engineering Research Council of Canada, Klohn Leonoff, Richmond; British Columbia Ministry of Transportation and Highways; Franki Canada, Richmond; members of the UBC In-Situ Testing Group, in particular D. Gillespie and P.K. Robertson, and the technical staff of the Civil Engineering Department, University of British Columbia, is very much appreciated.

References

- American Petroleum Institute (1980), "Recommended Practice for Planning, Designing, and Constructing Fixed Offshore Platforms, API RP 2A, 11th edition.
- Blunden, R.H. (1975), "Urban Geology of Richmond, British Columbia," Adventures in Earth Sciences Series No. 15, B.C. Govt. Publications.
- Brierley, G.S., Thompson, D.E., and Eller, C.W. (1979), "Interpreting End-Bearing Pile Load Test Results," Behaviour of Deep Foundations, ASTM STP 670. Raymond Lundgren, Ed., American Society for Testing and Materials, pp. 181-198.
- Brough, N.W.A. (1982), "The Analysis of Cone Resistance ' q_c ' and Sleeve Friction ' f_s ' as Interactive Stresses, Resulting in a New Pile capacity Design Method," Penetration Testing, Proc. 2nd European Symp. Penetration Testing, ESOPT II, Amsterdam, Vol. 2, pp. 469-478.
- Brown, S.G. (1983), "In-situ Testing Techniques Applied to Embankments over Soft Organic Soils," M.A.Sc. Thesis, University of British Columbia, Department of Civil Engineering, October, 1983.
- Burland, J.B. (1973), "Shaft Friction of Piles in Clay - A Simple Fundamental Approach," Ground Engineering, Vol. 6, No. 3, pp. 30-42.

- Bustamante, M. and Gianceselli, L. (1982), "Pile Bearing Capacity Prediction by means of Static Penetrometer CPT," Penetration Testing, ESOPT II, Amsterdam, Vol. 2, pp. 493-500.
- Campanella, R.G. and Robertson, P.K. (1983), "Flat Plate Dilatometer Testing: Research and Development at UBC," First International Conference on the Flat Plate Dilatometer, Edmonton, Alberta, Canada, 4 February, 1983.
- Campanella, R.G. and Robertson, P.K. (1986), "Research and Development of the UBC Cone Pressuremeter (for the Offshore)," Contribution to 3rd Canadian Conference on Marine Geotechnical Engineering, Memorial University, St. John's, Newfoundland, June 11-13, 1986.
- Davisson, M.T. (1973), "High Capacity Piles," Proceedings, Lecture Series, Innovations in Foundation Construction, ASCE, Illinois Section, Chicago, 52 pp.
- de Beer, E.E. (1963), "The Scale Effect in Transportation of the Results of Deep Sounding Tests on the Ultimate Bearing Capacity of Piles and Caisson Foundations," Geotechnique, Vol. 8, p. 39.
- Dennis, N.D. and Olson, R.E. (1984b), "Axial Capacity of Steel Pipe Piles in Sand," Am. Soc. of Civil Engrs., Geotechnical Practice in Offshore Engineering, Austin, pp. 389-402.
- de Ruiter, J. and Beringen, F.L. (1979), "Pile Foundations for Large North Sea Structures," Marine Geotechnology, Vol. 3, No. 4, pp. 267-314.
- Fellenius, B.H. (1980), "The Analysis of Results from Routine Pile Test Loading," Ground Engineering, Foundation Publications Ltd., London, Vol. 13, No. 6, pp. 19-31.
- Flaate, K., and Selnes, P. (1977), "Side Friction of Piles in Clay," Proceedings of Ninth International Conference on Soil Mechanics and Foundation Engineering, Tokyo, Japan, Vol. 1, pp. 517-522.

- Hughes, J.M.O. and Robertson, P.K. (1985), "Full-displacement pressuremeter testing in sand," Canadian Geotechnical Journal, Volume 22, No. 3, August 1985, pp. 298-307.
- Janbu, N. (1976), "Static Bearing Capacity of Friction Piles," Proceedings of the European Conference on Soil Mechanics and Foundation Engineering, Vol. 1.2, pp. 479-488.
- Marchetti, S. (1980), "In-situ Tests by Flat Dilatometer," ASCE Journal of Geotechnical Engineering Division, Vol. 106, No. GT3, pp. 299-321.
- Matlock, H. (1970), "Correlations for Design of Laterally Loaded Piles in Soft Clay," Proc. 2nd Offshore Tech. Conf., Texas, Vol. 1, pp. 557-594.
- Meyerhof, G.G. (1951), "The Ultimate Bearing Capacity of Foundations," Geotechnique, Vol. 2, No. 4, p. 301.
- Meyerhof, G.G. (1976), "Bearing Capacity and Settlement of Pile Foundations," ASCE Journal of Geotechnical Engineering Division, Vol. 102, No. GT3, pp. 197-228.
- Mitchell, J.K., Guzikowski, F. and Villet, W.C.B. (1978), "The Measurement of Soil Properties In-situ," Report prepared for U.S. Department of Energy Contract W-7405-ENG-48, Lawrence Berkeley Laboratory, University of California, Berkeley, CA 94720, March 1978, 67 pp.
- Nottingham, L.C. (1975), "Use of Quasi-Static Friction Cone Penetrometer Data to Predict Load Capacity of Displacement Piles," Ph.D. dissertation, Dept. of Civil Engineering, University of Florida.
- Reece, L.C. and Sullivan, W.R. (1970), "Documentation of Computer Program COM624," Bureau of Engineering Research, University of Texas at Austin, Texas.
- Robertson, P.K. (1985), "Ins-situ Testing and its application to Foundation Engineering," Colloquium presented at the 38th Canadian Geotechnical Conference, Edmonton.

Robertson, P.K. and Campanella, R.G. (1986), "Guidelines for Use and Interpretation of the CPT and CPTU, Dept. of Civil Engineering, Soil Mechanics No. 105, University of British Columbia.

Robertson, P.K., Davies, M.P. and Campanella, R.G. (1987), "Design of Laterally Loaded Driver Piles Using the Flat Plate Dilatometer," Soil Mechanics Series, Department of Civil Engineering, the University of British Columbia.

Robertson, P.K., Hughes, J.M.O., Campanella, R.G., Brown, P. and McKeown, S. (1986), "Design of Laterally Loaded Piles Using the Pressuremeter," The Pressuremeter and its Marine Applications: Second International Symposium, ASTM STP 950, J-L Briaud and J.M.E. Audibert, Eds., American Society for Testing and Materials, pp. 443-457.

Schmertmann, J.H. (1986), "Suggested Method for Performing the Flat Dilatometer Test," Geotechnical Testing Journal, GT-JODJ, Vol. 9, No. 2, June 1986, pp. 93-101.

Schmertmann, J.H. (1978), "Guidelines for Cone Penetration Test, Performance and Design," Federal Highway Administration, Report FHWA-TS-78-209, Washington, July 1978, 145 pp.

Van Mierlo, W.C. and Koppejan, A.W. (1952), "Lengte en Draagvermogen van Heipalen," Bouw, 19 Jan. 1952.

Vijayvergiya, V.A. and Focht, J.A., "A New Way to Predict Capacity of Piles in Clays," Proceedings of Fourth Offshore Technology Conference, Houston, Vol. 2, pp. 865-874.

Wroth, C.P. (1984), "The Interpretation of In-situ Soil Tests," Geotechnique, 34, No. 4, pp. 449-489.

Zhou, J., Xie, Y., Zuo, Z.S., Luo, M.Y. and Tang, X.J. (1982), "Prediction of Limit Load of Driven Pile by CPT," Penetration Testing, Proc. 2nd European Symp. Penetration Testing, ESOPIT II, Amsterdam, Vol. 2, pp. 957-961.

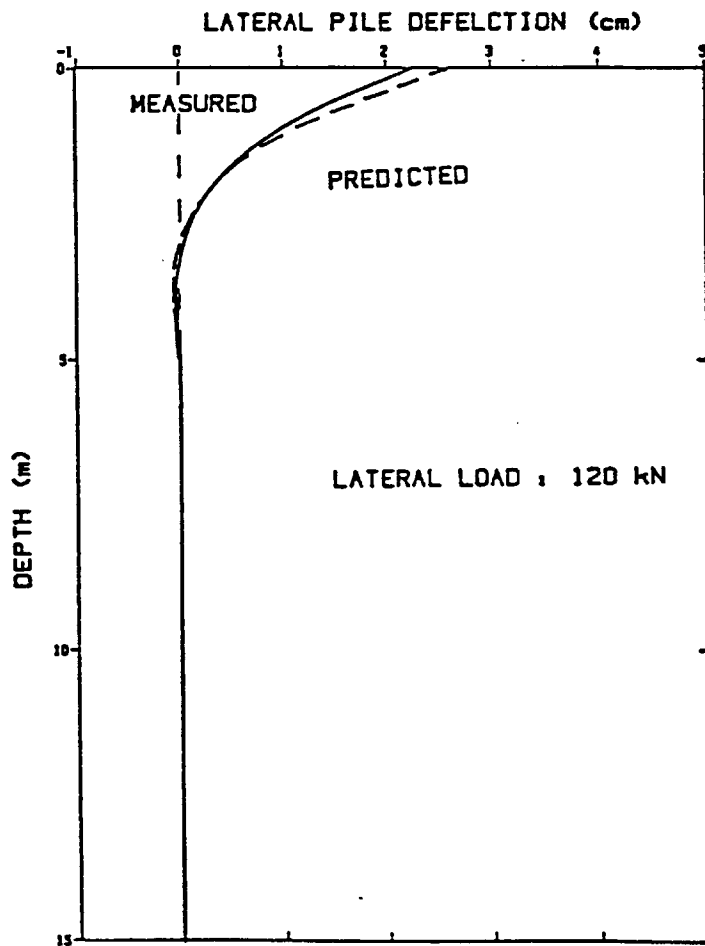
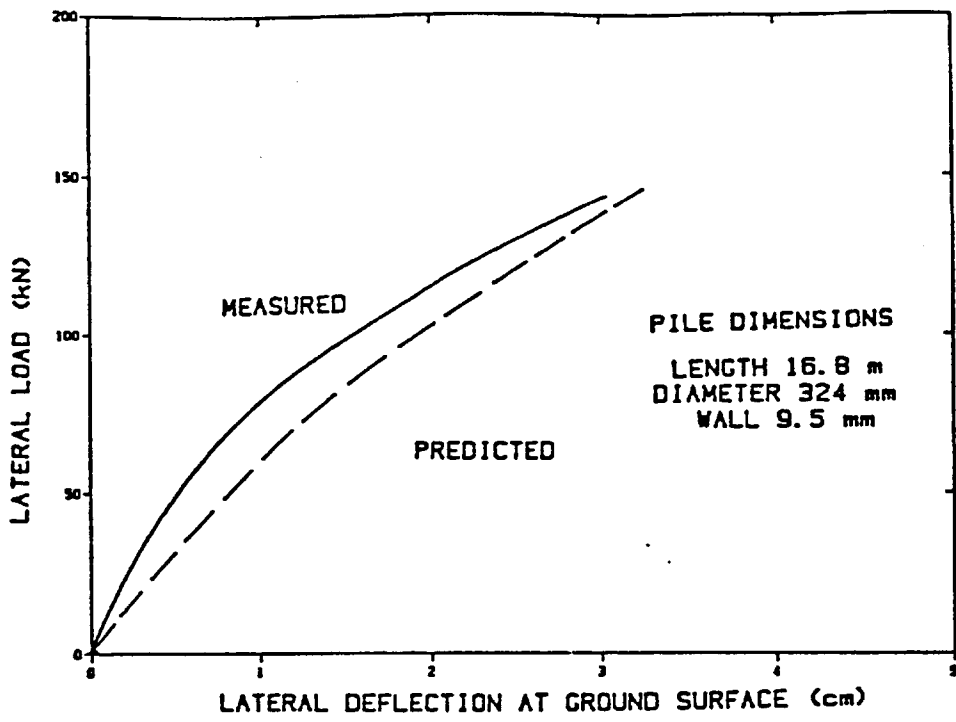

Fig. 23. Predicted Versus Measured Lateral Pile Behaviour: UBC Pile Research Site Using DMT